

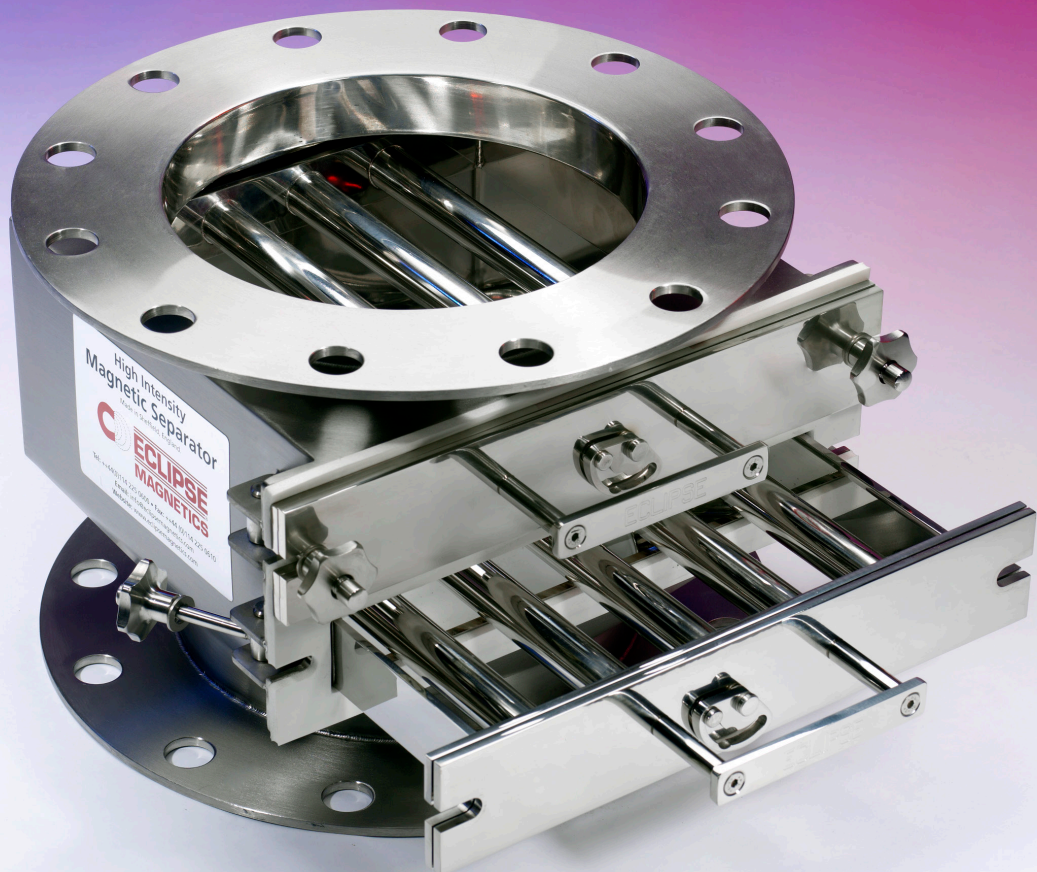

Foreign Body Removal

Magnetic Separation & Metal Detection Systems





Introduction To Eclipse Magnetics

Over 100 Years of Manufacturing Excellence



Serving some of the leading names in processing, including:

- Nestlé
- Mondelez
- PepsiCo
- Kellogg's
- Weetabix
- Rank Hovis
- Premier Foods
- Allied Bakeries
- Unilever
- Warburtons
- Mars
- Pfizer
- GlaxoSmithKline
- Genzyme
- Roche
- AstraZeneca

Innovation in Magnetic Technology

With 100 years of experience in the design and manufacture of high performance magnetic systems, we supply critical equipment to some of the leading names in the most demanding industries.

Our magnetic technology is widely used at leading worldwide companies and in major development projects, all requiring a guarantee of equipment performance.

Designing Excellence

We have track record of producing high quality products backed by a commitment to total customer service. Our technical application teams have a wealth of experience, thus ensuring many of our products are market leading innovations.

All manufacturing is carried out under an ISO 9001 certified quality management system and we are accredited to ISO 14001 environmental standards.

Unrivalled Product Range

We serve worldwide markets with an extensive product range including workholding systems, filtration systems, foreign body removal systems, magnetic assemblies and complex magnetic industrial equipment used in industries such as automotive, aerospace, food processing and nuclear.

Many of our products are unique and are covered by global patents.

Process Protection

Magnetic Separation & Metal Detection Systems

Managing Risk – Process Safety

One of the greatest challenges to processing industries is ensuring maximum integrity of the finished product. Failure to do so can be catastrophic with the real risk of causing personal harm to the consumer, product scrappage/recall costs and high profile brand damage.

To protect themselves, major retailers now ask their suppliers to implement safety management systems. Hazard Analysis and Critical Control Point (HACCP) is an internationally recognized system for reducing the risk of safety hazards.

Our magnetic separation systems are integral to HACCP in almost every processing industry. They remove ferrous and para-magnetic (including stainless steel) contamination from process lines, preventing product contamination and damage to machinery.

We produce high-quality, high-power magnetic separators for most applications, including bulk grain, dry powders, damp powders, liquids and syrups and a comprehensive range of metal detectors.



We offer a range of benefits:

Experience

With over 30 years' experience we are perfectly placed to offer a range of separation and detection systems which are integral to process safety across a variety of industries.

Knowledge

We pride ourselves on understanding the business of our customers, the risks they face and changing market requirements.

Flexibility

The ability to offer a flexible and responsive solution, enabling short lead times to reactive requirements and ensuring process safety is never compromised.

Advancement

From simple manually cleaned units to fully automated touch screen PLC controlled systems, we can offer the latest designs and technology available.

Multi-Site Strategies

We offer group wide solutions for multi-site organisations, specialising in final product improvement and risk management.

A Single Source

Our clients can deal with a single source for separation and detection solutions, catering for all stages of production and process volumes.

Bespoke Design

Utilising the latest 3D design software, we can produce bespoke systems in short lead times.

High Quality Manufacture

Using the latest magnetic technology and surface finishing techniques we produce high quality systems suitable for use in food or pharmaceutical environments.

Standards

We are fully conversant with all major food safety policies such as FSA, FDA and IFS. Plus other institutes such as BRC and GFSI.



In-house ATEX Certification

EU Directive 94/9/EC

In addition to high performance products, a major benefit of working with Eclipse Magnetics is that we are one of the few manufacturers who manufacture and certify ATEX approved equipment in-house. Most manufacturers have to submit to an external independent test house, thereby incurring additional cost and extending lead times.

We supply fully certified equipment for use in zones 20, 21, 22 or gas zone 0, 1 and 2 environments. ATEX product certification (or EC Type Examination) is a check on the design specification of a product in relation to a series of relevant standards laid out under the directive.

It involves detailed examination, testing and assessment of equipment intended for use in potentially hazardous areas, with the end result being the issue of an ATEX certificate and report, confirming and demonstrating that the product is safe to use (within certain parameters) within potentially explosive atmospheres.

The certification process must be undertaken by an approved organisation such as Eclipse Magnetics.

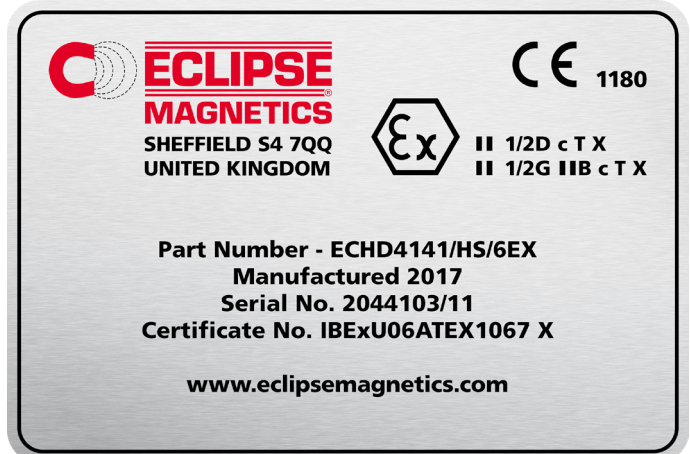

ECLIPSE MAGNETICS
SHEFFIELD S4 7QQ
UNITED KINGDOM

CE 1180

Ex II 1/2D c T X
II 1/2G IIB c T X

Part Number - ECHD4141/HS/6EX
Manufactured 2017
Serial No. 2044103/11
Certificate No. IBExU06ATEX1067 X

www.eclipsemagnetics.com

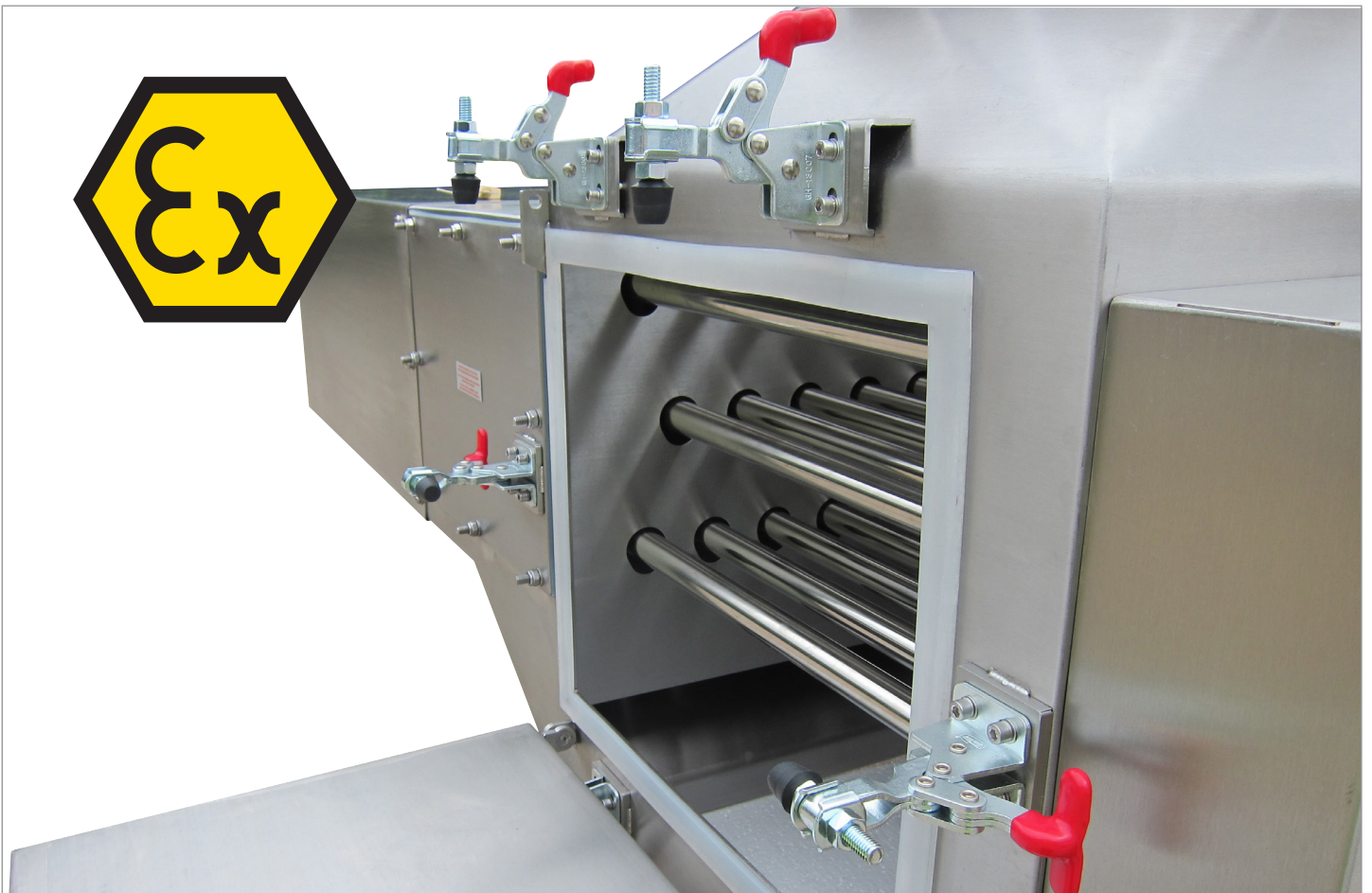

Foreign Body Removal

Find Your Solution

Our range of Foreign Body Removal systems encompasses products for a variety of applications.

Use the chart below to find the most suitable system for your application.



Secondary Separators

Secondary separators guarantee product purity and quality by removing sub-micron ferrous particles e.g, process equipment wear. This includes paramagnetic stainless steel particles. Secondary separators also remove residual primary contamination

Product	Typical Applications						Selection Criteria						Page
	Food	Chemical	Pharmaceutical	Plastics	Recycling	Wood	ATEX Approved	Gravity Feed	Pneumatic Feed	Conveyor Feed	Manual Clean	Automatic Clean	
Magnetic Rod	✓	✓	✓	✓	—	—	✓	✓	✓	—	✓	—	P9
Sampling Probe	✓	✓	✓	✓	—	—	—	—	—	—	✓	—	P11
Square / Circular Grid	✓	✓	✓	✓	—	—	✓	✓	—	—	✓	—	P13
Sieve Magnet	✓	✓	✓	—	—	—	—	✓	—	—	✓	—	P15
Easy Clean Grid	✓	✓	✓	✓	—	—	✓	✓	—	—	✓	—	P17
Housed Easy Clean Grid	✓	✓	✓	✓	—	—	✓	✓	—	—	✓	—	P19
Auto Shuttle	✓	✓	✓	✓	—	—	✓	✓	—	—	—	✓	P24
Rota-Grid	✓	✓	✓	✓	—	—	✓	✓	—	—	✓	—	P28
Auto-Rota Shuttle	✓	✓	✓	✓	—	—	✓	✓	—	—	—	✓	P30
Pneumag	✓	✓	✓	✓	—	—	✓	—	✓	—	✓	—	P32
EHEDG Magnetic Separator	✓	✓	✓	✓	—	—	✓	✓	✓	—	✓	—	P34
In-line Liquid Filter	✓	✓	✓	N/A	N/A	N/A	✓	N/A	N/A	N/A	✓	✓	P36

Primary Separators

Primary separators prevent machinery damage by removing 'Tramp' type contamination such as nuts, bolts and screws. Typically installed at bulk intake points, our range is shown below

Product	Typical Applications						Selection Criteria						Page
	Food	Chemical	Pharmaceutical	Plastics	Recycling	Wood	ATEX Approved	Gravity Feed	Pneumatic Feed	Conveyor Feed	Manual Clean	Automatic Clean	
Strip Magnet	✓	✓	✓	✓	✓	✓	✓	—	—	✓	✓	—	P38
Underflow Magnet	✓	✓	✓	✓	✓	✓	—	✓	—	✓	✓	—	P40
Housed Underflow Magnet	✓	✓	✓	✓	✓	✓	✓	✓	✓	—	✓	—	P42
Bullet Magnet	✓	✓	✓	✓	✓	✓	—	✓	✓	—	✓	—	P44
Chute Magnet	✓	✓	✓	✓	✓	✓	✓	✓	✓	—	✓	—	P46
Drum Magnet	✓	✓	✓	✓	✓	✓	—	✓	—	✓	—	✓	P48
Housed Drum Magnet	✓	✓	✓	✓	✓	✓	✓	✓	—	✓	—	✓	P50
Permanent Head Roller	✓	✓	✓	✓	✓	✓	—	—	—	✓	—	✓	P52
Permanent Plate Magnet	✓	✓	✓	✓	✓	✓	✓	—	—	✓	✓	—	P54
Permanent Magnetic Overband	✓	✓	✓	✓	✓	✓	—	—	—	✓	—	✓	P56

A Choice Of Systems

Primary & Secondary Separators

The following pages detail our range of options which protect against all types of ferrous contamination.

Featured Products

Our most popular separation options are highlighted below:

Easy Clean Housed Grids

Ideal for the removal of fine iron and para-magnetic contamination from a range of dry free flowing or gravity fed products such as grain, flour, granulates and powders. Available in a range of sizes and multi-row magnet configurations.

[Find out more on page 19](#)

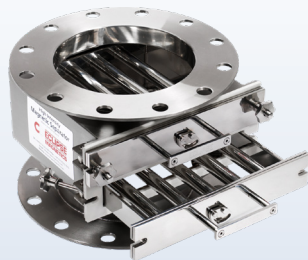

Autoshuttle

With an automated cleaning function, the Autoshuttle enables 24/7 screening of processed free flowing dry granulates and powders such as sugar and salt.

[Find out more on page 24](#)



Pneumag Separator

A high intensity separator, designed to operate on pneumatic dry powder or granulate conveying lines to provide protection against ferrous and para-magnetic contamination.

[Find out more on page 32](#)



High Intensity Liquid Filter

Designed to operate in pressurised transfer lines to remove ferrous and para magnetic particles from liquid processing lines. For items such as chocolate, syrup, jam, pastes and beverages.

[Find out more on page 34](#)



Rota-Grid

High intensity separator which removes ferrous contamination from substances which are prone to caking or bridging e.g. starch and proteins. The rotating action ensures a continued flow with no blockages.

[Find out more on page 28](#)



Magnetic Rod



At A Glance



Protection: Secondary



Material Type: NdFeB



Cleaning Type: Manual

Our high intensity Rare Earth magnetic rods are extremely efficient at removing ferrous and para-magnetic contamination, down to sub-micron size, from free flowing products including powders and liquids.

Rods are of particular interest to those who wish to incorporate them into their machinery with the minimal amount of engineering.

Each rod is tapped with an M6 thread at both ends as standard for ease of installation, or alternatively without threaded detail or with studs, which can be specified on ordering.

Many sizes are held in stock to allow for same day despatch.



Benefits

- Easy to clean
- Simple to use
- Enables flexible design
- Removes micron sized contaminants

Performance

Magnetic Performance	7000, 9000, 11000 and 12000 Gauss
Performance Reading	On tube surface
Magnet Grade	N35 & N45 – Inspected and confirmed via hysteresigraph prior to use
Temperature	-20°C / +90°C

Suitability

Suitable Products	All powders, granulates and liquids
Suitable Location	Any process area

Materials

Magnetic Material	Rare Earth Neodymium Iron Boron - (NdFeB)
Tubing	316 grade stainless steel
Other Parts	316 grade stainless steel
Surface Finish	Polished to 0.6µm
Rod End Detail	Tapped M6 x 8mm both ends

Cleaning

Depending on the configuration, rod magnets can be cleaned in seconds by simply pushing the attracted contamination to one end, this will release it enabling further analysis to be conducted.

Options

- Any thread size and detail
- Supplied without tapped detail or studded
- ATEX certified
- Pharmaceutical specification
- Higher temperature versions available

Magnetic Rod

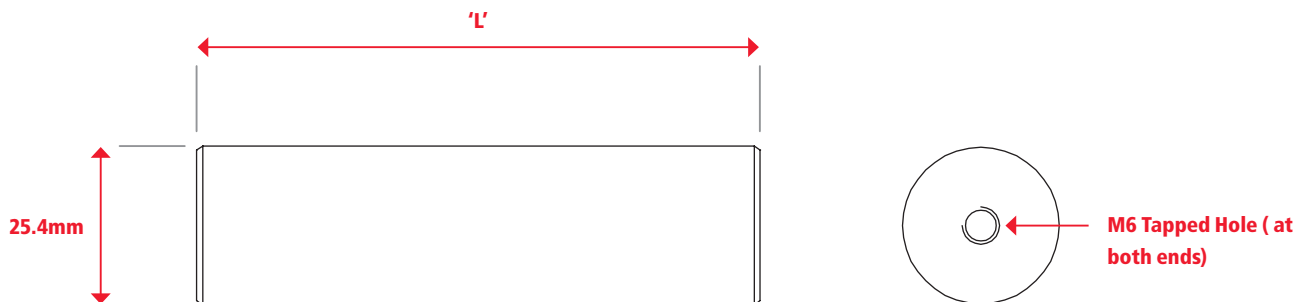

Part Number	L (mm)	Weight (kg)
SR100	100	0.35
SR150	150	0.53
SR200	200	0.70
SR250	250	0.88
SR300	300	1.05
SR350	350	1.23
SR400	400	1.40
SR450	450	1.58
SR500	500	1.75
SR550	550	1.93
SR600	600	2.10
SR650	650	2.28
SR700	700	2.45
SR750	750	2.63
SR800	800	2.80
SR850	850	2.98
SR900	900	3.15
SR950	950	3.33
SR1000	1000	3.50

For non-standard sizes, please contact sales@eclipsemagnetics.com

Sampling Probe

At A Glance



Protection: Secondary



Material Type: NdFeB



Cleaning Type: Manual

Our high intensity magnetic sampling probe is ideal for quality control personnel to quickly and easily carry out product purity inspections on any powder, granulate or liquid for ferrous or para-magnetic contamination.

The probe should be used for sample inspection of product at goods inward, prior to despatch and at critical control points throughout the process line for batch testing.

Simply allow the processed product to pass over the magnetic section of the probe or agitate in any static product. Any ferrous or para-magnetic contamination present will be highly visible when concentrated on the probe's surface.



Benefits

- Easy to clean
- Meets audit requirements
- Simple to use
- Indicates if contamination present
- Removes micron sized contaminants

Performance

Magnetic Performance	9000 Gauss
Performance Reading	On tube surface
Magnet Grade	N45 – Inspected and confirmed via hysteresigraph prior to use
Temperature	-20°C / +90°C

Suitability

Suitable Products	All powders, granulates and liquids
Suitable Location	Existing sampling points

Materials

Magnetic Material	Rare Earth Neodymium Iron Boron - (NdFeB)
Tubing	316 grade stainless steel
Other Parts	316 grade stainless steel
Surface Finish	Polished to 0.6µm

Cleaning

Remove the unit from the sampling area and, while holding the body of the probe, simply pull the rear handle backwards. This will release any attracted contamination enabling further analysis to be conducted.

Options

- Pharmaceutical specification
- Magnet lengths up to 500mm
- Higher temperature versions available

Sampling Probe

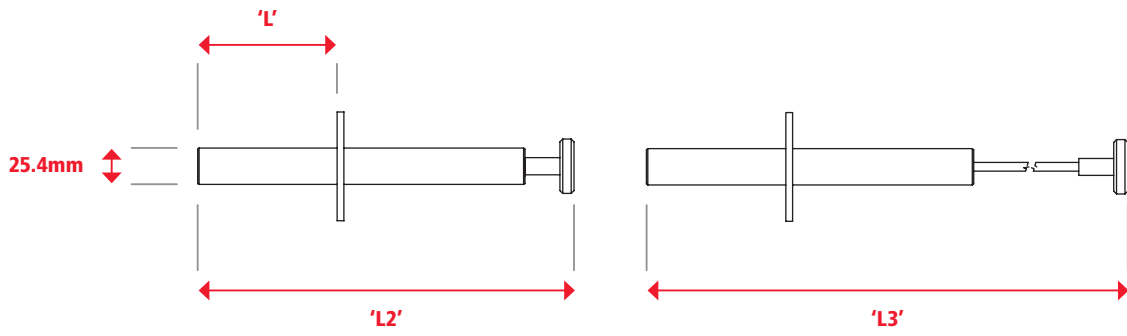

Part Number	L (mm)	L2 (mm)	L3 (mm)	Weight (kg)
MSP100	100	270	400	0.9
MSP200	200	470	700	1.2
MSP300	300	670	1000	1.6

For non-standard sizes, please contact sales@eclipsemagnetics.com

At A Glance



Protection: Secondary



Feed Type: Gravity



Material Type: NdFeB



Cleaning Type: Manual

High intensity grids are very versatile and can be used in most powder, granulate and liquid applications for the removal of ferrous and para-magnetic contamination down to sub-micron size.

These units can be manufactured to any size and with any number of rods to meet most application requirements.

The grids' low profile side frame means they can be installed into existing chute work or machinery where height is restricted.

Grids are of particular interest to OEMs who wish to incorporate them into their machinery with the minimal amount of redesign.



Benefits

- Simple to install
- Removes micron sized contaminants
- Reduces 'spark' risk
- Meets audit requirements

Performance

Magnetic Performance	7000, 9000, 11000 and 12000 Gauss
Performance Reading	On tube surface
Magnet Grade	N35 & N45 – Inspected and confirmed via hysteresigraph prior to use
Temperature	-20°C / +90°C

Suitability

Suitable Products	Dry powders and granulates
Suitable Location	Vertical or angled process lines

Materials

Magnetic Material	Rare Earth Neodymium Iron Boron - (NdFeB)
Tubing	316 grade stainless steel
Other Parts	316 grade stainless steel
Surface Finish	Polished to 0.6µm

Cleaning

Due to the high intensity magnetic field and simple design, fixed grids require more effort to clean than the Eclipse Magnetics 'easy clean' design. Remove the grid from its process position and push the contamination down each rod. This will release the majority of all attracted contamination.

Options

- Pharmaceutical specification
- Larger sizes available
- Higher temperature versions available

Circular / Square Grid

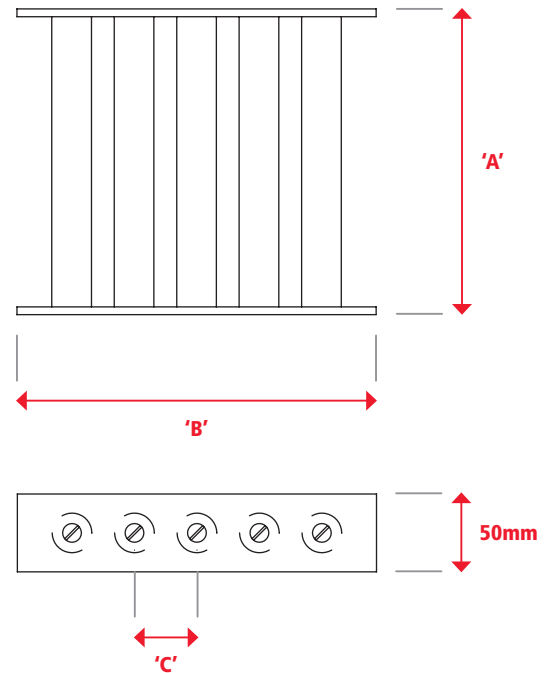
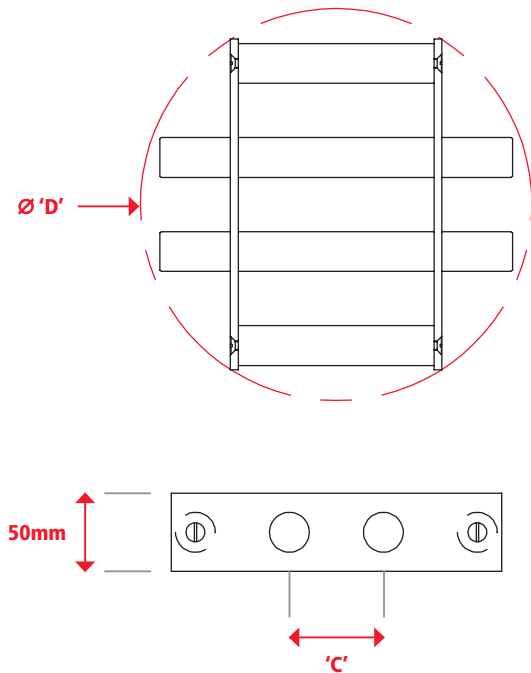

Part Number (Circular)	Diameter (mm)	Centres C (mm)	Number Of Rods	Weight (kg)
CG100	100	45	2	1.2
CG150	150	50	3	1.5
CG200	200	60	3	2.2
CG250	250	60	4	3.7
CG300	300	60	5	5.0
CG350	350	60	6	7.0
CG400	400	60	7	9.5
CG450	450	60	7	14
CG500	500	60	8	17
CG550	550	60	9	20
CG600	600	60	10	24

Part Number (Square)	A (mm)	B (mm)	C (mm)	Number Of Rods	Weight (kg)
GM1515	150	150	60	2	3.2
GM2020	200	200	60	3	3.8
GM2525	250	250	55	4	6.2
GM3030	300	300	55	5	8.0
GM3535	350	350	55	6	11.0
GM4040	400	400	55	7	14.8
GM4545	450	450	55	8	19.2
GM5050	500	500	55	9	21.0
GM5555	550	550	55	10	23
GM6060	600	600	55	11	27

For non-standard sizes, please contact sales@eclipsemagnetics.com

Sieve Magnet

At A Glance



Protection: Secondary



Feed Type: By Sieve



Material Type: NdFeB



Cleaning Type: Manual

Our sieve magnet is a unique lightweight, full stainless steel design which reduces the stress on the sieve that other types often cause.

The unit is positioned beneath the sieve screen allowing excellent separation to be achieved. Due to the high intensity of the magnetic field within the unit, even sub-micron sized particles generated by the wear of the sieve screen can be successfully attracted.



Benefits

- Easy to install
- Removes micron sized contaminants
- Reduces 'spark' risk
- Protects against screen wear and failure
- Meets audit requirements
- Static dissipative all metal construction

Performance

Magnetic Performance	7000, 9000, 11000 and 12000 Gauss
Performance Reading	On tube surface
Magnet Grade	N35 & N45 – Inspected and confirmed via hysteresigraph prior to use
Temperature	-20°C / +90°C

Suitability

Suitable Products	Dry powders, granulates and liquids etc.
Suitable Location	Post sieve screen

Materials

Magnetic Material	Rare Earth Neodymium Iron Boron - (NdFeB)
Tubing	316 grade stainless steel
Other Parts	316 grade stainless steel
Surface Finish	Polished to 0.6µm

Cleaning

Simply remove the top pan and screen from the sieve. The magnet can now be removed from the bottom pan and placed onto a non-magnetic surface. Using the supplied cleaning tool, simply scrape all attracted contamination to each rod end where it can be removed.

Options

- Pharmaceutical specification
- Magnet and screen metal detectable silicon rubber seal
- Higher temperature versions available

Sieve Magnet

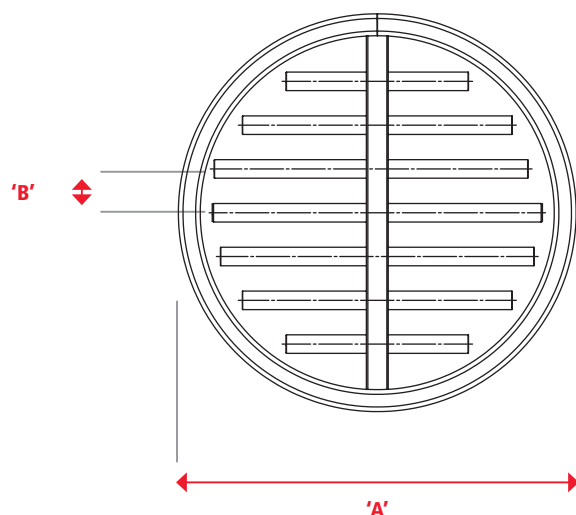

Part Number	A (mm)	B (mm)	Number Of Rods	Weight (kg)	Gauss	To Be Used In Types
SU600/M/SS	545	55	7	14	7,000	RussellFinex - Compact
SU600/M/HS	545	55	7	14	9,000	RussellFinex - Compact
SU600/M/SHS	545	55	7	14	11,000	RussellFinex - Compact
SU600/M/12K						

For non-standard sizes, please contact sales@eclipsemagnetics.com

Metal Detectable Seal

The Eclipse Magnetics metal detectable sieve magnet and screen seal is a patented rubber seal that allows for easy detection in case of breakage due to excessive sieve wear.

The magnet and screen seal differ in size and can be fitted to the patented sieve magnet. These seals can also be retro fitted to existing sieve magnets and screens from leading manufacturers. All materials used to manufacture these seals are listed in the FDA regulations.



At A Glance

-  **Protection: Secondary**
-  **Feed Type: Gravity**
-  **Material Type: NdFeB**
-  **Cleaning Type: Manual**

Our high intensity easy clean grid is very versatile and can be utilised in most powder and granulate applications for the removal of ferrous and para-magnetic contamination down to sub-micron size.

These units can be manufactured to any size and with any number of rods to meet most application requirements.

The grid's low profile side frame allows these units to be installed into existing chute work or machinery where height is restricted. Easy clean grids can be cleaned in under fifteen seconds, so are of particular interest to those companies that run 24/7 operations or where downtime is minimal.

These grids can also be supplied in housings for ease of installation into existing process lines.



Benefits

- Simple to install
- Removes micron sized contaminants
- Reduces 'spark' risk
- Meets audit requirements

Performance

Magnetic Performance	7000, 9000 and 10000 Gauss
Performance Reading	On tube surface
Magnet Grade	N35 & N45 – Inspected and confirmed via hysteresigraph prior to use
Temperature	-20°C / +90°C

Suitability

Suitable Products	Dry powders, granulates and liquids etc
Suitable Location	Any vertical or slightly angled process line

Materials

Magnetic Material	Rare Earth Neodymium Iron Boron - (NdFeB)
Tubing	316 grade stainless steel
Other Parts	316 grade stainless steel
Swing Clamps	304 grade stainless steel
Surface Finish	Polished to 0.6µm

Cleaning

Simply move the swing clamp to the 'open' position, pull the magnetic cores out of the stainless steel tube assembly and the contamination simply falls away. It is at this stage that all attracted contamination can be easily removed allowing for inspection or further analysis.

Options

- Pharmaceutical specification
- Larger sizes available
- Safety relay switch
- ATEX certified
- Higher temperature versions available

Easy Clean Grid

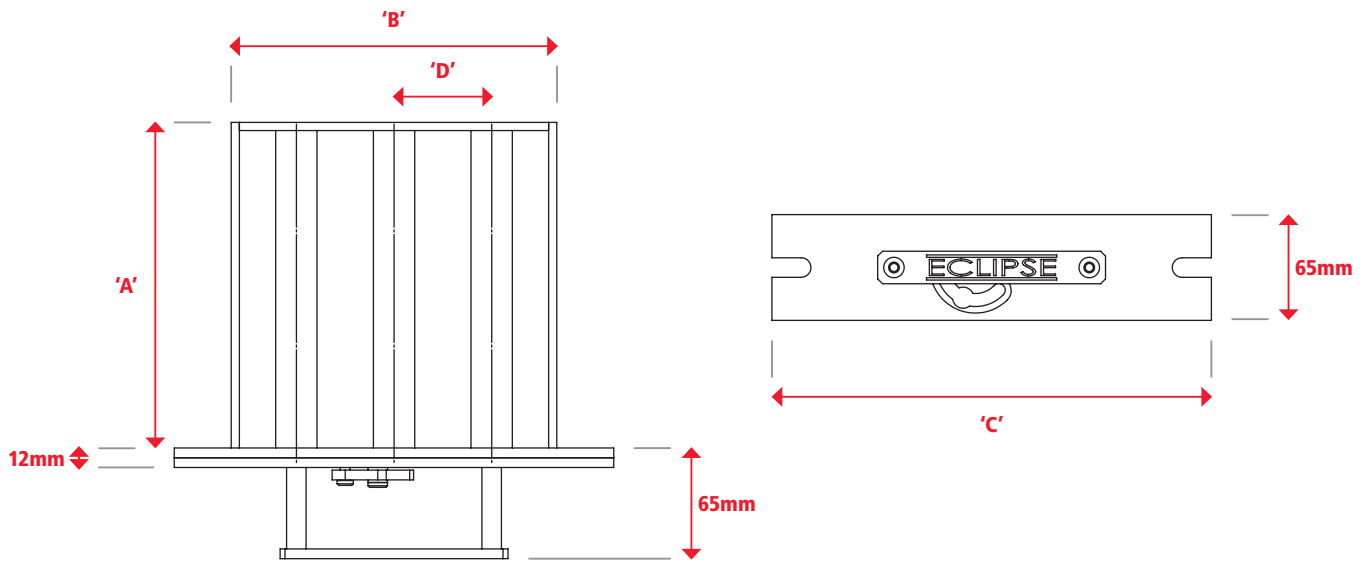

Part Number	Length A (mm)	Width B (mm)	Width C (mm)	Centres D (mm)	Number of Rods	Weight (kg)
EC1515	150	150	220	60	2	3.8
EC2020	200	200	270	60	3	4.2
EC2525	250	250	320	55	4	6.8
EC3030	300	300	370	55	5	8.6
EC3535	350	350	420	55	6	12.0
EC4040	400	400	470	55	7	16.3
EC4545	450	450	520	55	8	21.1
EC5050	500	500	570	55	9	25.0
EC5555	550	550	620	55	10	29.5
EC6060	600	600	670	55	11	34.25

For non-standard sizes, please contact sales@eclipsemagnetics.com

Housed Easy Clean Grid



At A Glance

- Protection: Secondary
- Feed Type: Gravity
- Material Type: NdFeB
- Cleaning Type: Manual

Our high intensity magnetic easy clean housed grids offer unsurpassed levels of contamination removal, removing sub-micron ferrous and para-magnetic contamination from the most demanding and arduous of process environments.

The unit contains one high intensity easy clean magnetic grid. The grid is secured into the housing by tri-cone locking nuts which ensure even pressure is generated around the food grade seal.

It is common to have numerous units installed throughout a processing facility to ensure contamination is removed at source of generation. All dry powders and granular type materials can be processed through the unit. Electrical safety interlocks can be fitted to the grid to stop the process should it be accidentally opened.



Benefits

- Easy to clean
- Removes micron sized contaminants
- High collection capacity
- Reduces 'spark' risk

Performance

Magnetic Performance	7000, 9000, 10000
Performance Reading	On tube surface
Magnet Grade	N35 & N45 – Inspected and confirmed via hysteresigraph prior to use
Temperature	-20°C / +90°C
Pressure	+ / - 0.2 Bar

Suitability

Suitable Products	Dry powders and granulates
Suitable Location	Inlet / outlet points, pre- / post-silo and machinery points

Materials

Magnetic Material	Rare Earth Neodymium Iron Boron - (NdFeB)
Housing	316 grade stainless steel
Tubing	316 grade stainless steel
Sealing	Self adhered white foam
Tri-cone Nuts	Stainless Steel
Surface Finish	Polished internally / Brushed externally to 0.6µm

Cleaning

When the unit requires cleaning, simply remove the outer grid securing tri-cone locking nuts and remove the grid from the housing. Remove the central tri-cone locking nut and separate the grid assembly allowing all attracted contamination to simply fall away.

Options

- Stainless Steel Toggle Clamps
- Larger sizes available
- Pharmaceutical specification
- Safety relay switches
- Metal Detectable Seal
- Higher temperature versions available

Housed Easy Clean Grid – Single

Round

Square

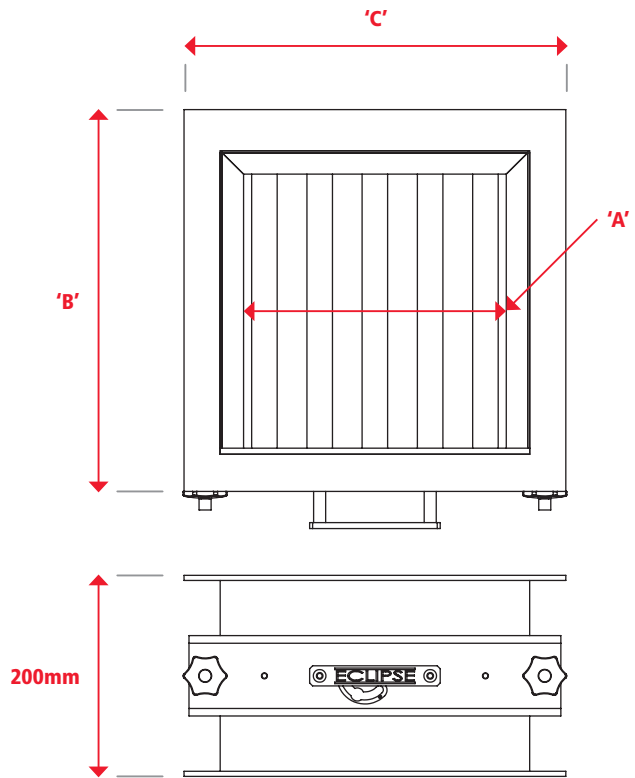
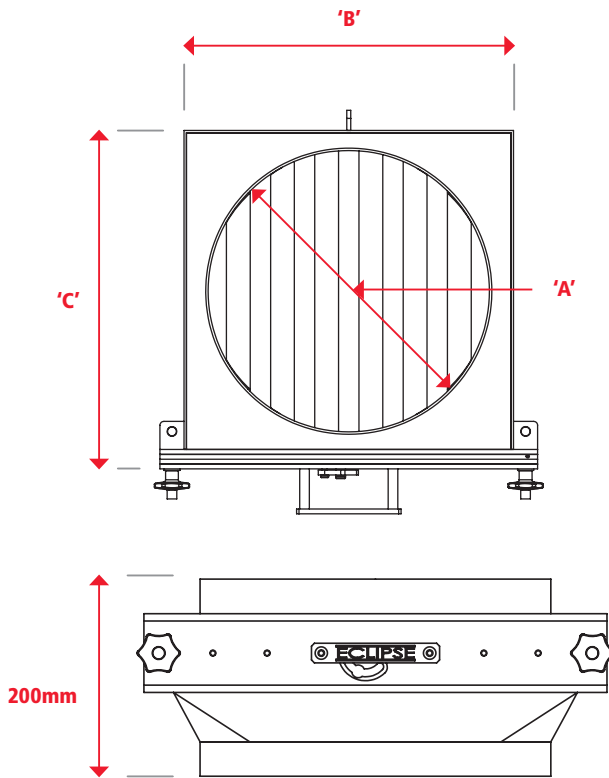

Part Number (Round)	A (mm)	B (mm)	C (mm)	Number Of Rods
ECHS100	100	158	168	2
ECHS150	150	208	218	3
ECHS200	200	258	268	4
ECHS250	250	308	318	5
ECHS300	300	358	368	6
ECHS350	350	408	418	7
ECHS400	400	460	470	8
ECHS450	450	510	520	9
ECHS500	500	560	570	10

Part Number (Square)	A (mm)	B (mm)	C (mm)	Number Of Rods
ECHS1515	150	230	230	2
ECHS2020	200	280	280	3
ECHS2525	250	330	330	4
ECHS3030	300	380	380	5
ECHS3535	350	430	430	6
ECHS4040	400	480	480	7
ECHS4545	450	530	530	8
ECHS5050	500	580	580	9

Other sizes available upon request

Housed Easy Clean Grid – Double

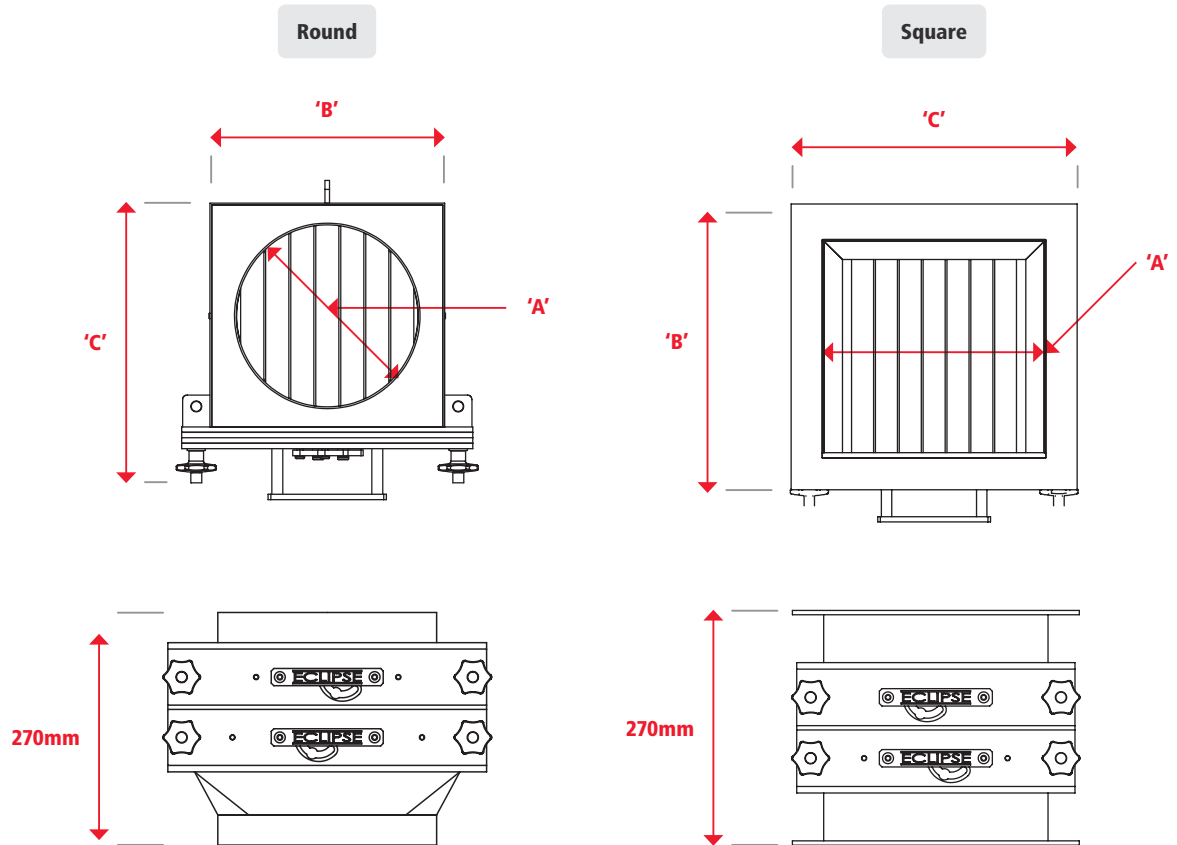

Part Number (Round)	A (mm)	B (mm)	C (mm)	Number Of Rods
ECHD100	100	158	168	1 + 2
ECHD150	150	208	218	2 + 3
ECHD200	200	258	268	3 + 4
ECHD250	250	308	318	4 + 5
ECHD300	300	358	368	5 + 6
ECHD350	350	408	418	6 + 7
ECHD400	400	458	470	7 + 8
ECHD450	450	508	520	8 + 9
ECHD500	500	558	570	9 + 10

Part Number (Square)	A (mm)	B (mm)	C (mm)	Number Of Rods
ECHD1515	150	230	230	1 + 2
ECHD2020	200	280	280	2 + 3
ECHD2525	250	330	330	3 + 5
ECHD3030	300	380	380	4 + 5
ECHD3535	350	430	430	5 + 6
ECHD4040	400	480	480	6 + 7
ECHD4545	450	530	530	7 + 8
ECHD5050	500	580	580	9 + 8

Other sizes available upon request

Housed Easy Clean Grid – Triple

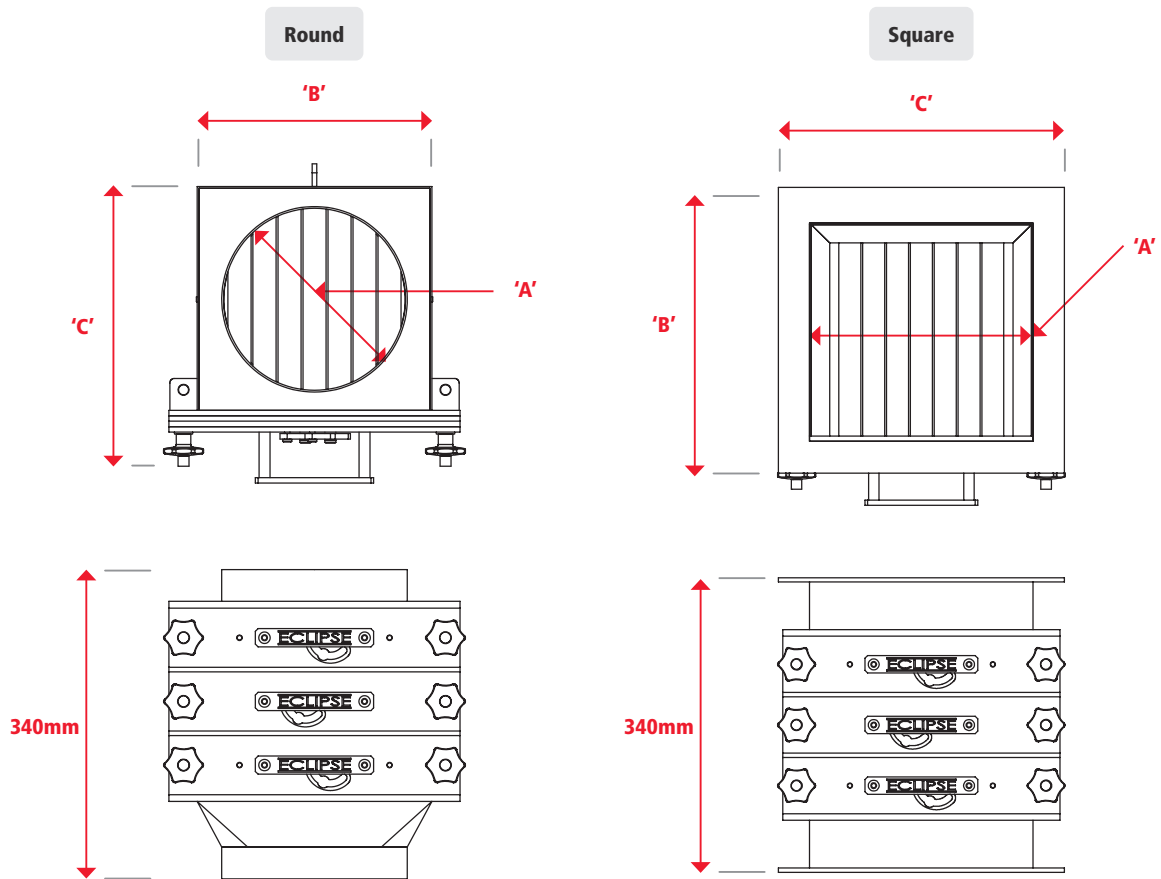

Part Number (Round)	A (mm)	B (mm)	C (mm)	Number Of Rods
ECHT100	100	160	171	1 + 2 + 1
ECHT150	150	210	221	2 + 3 + 2
ECHT200	200	260	271	3 + 4 + 3
ECHT250	250	310	321	4 + 5 + 4
ECHT300	300	360	371	5 + 6 + 5
ECHT350	350	410	421	6 + 7 + 6
ECHT400	400	460	471	7 + 8 + 7
ECHT450	450	510	521	8 + 9 + 8
ECHT500	500	560	571	9 + 10 + 9

Part Number (Square)	A (mm)	B (mm)	C (mm)	Number Of Rods
ECHT1515	150	230	230	1 + 2 + 1
ECHT2020	200	280	280	2 + 3 + 2
ECHT2525	250	330	330	3 + 4 + 3
ECHT3030	300	380	380	4 + 5 + 4
ECHT3535	350	430	430	5 + 6 + 5
ECHT4040	400	480	480	6 + 7 + 6
ECHT4545	450	530	530	7 + 8 + 7
ECHT5050	500	580	580	8 + 9 + 8

Other sizes available upon request

Housed Easy Clean Grid – Quadruple

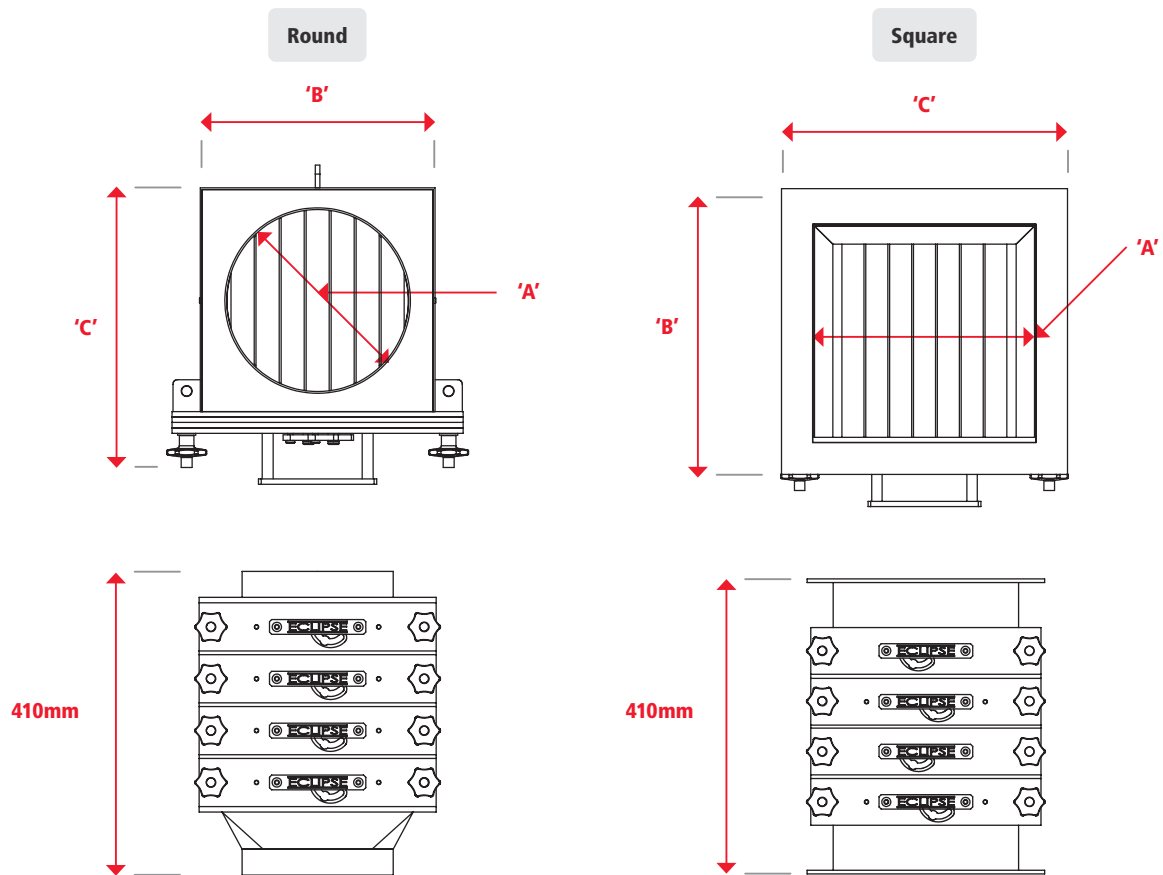

Part Number (Round)	A (mm)	B (mm)	C (mm)	Number Of Rods
ECHQ100	100	160	171	1 + 2 + 1 + 2
ECHQ150	150	210	221	2 + 3 + 2 + 3
ECHQ200	200	260	271	3 + 4 + 3 + 4
ECHQ250	250	310	321	4 + 5 + 4 + 5
ECHQ300	300	360	371	5 + 6 + 5 + 6
ECHQ350	350	410	421	6 + 7 + 6 + 7
ECHQ400	400	460	471	7 + 8 + 7 + 8
ECHQ450	450	510	521	8 + 9 + 8 + 9
ECHQ500	500	560	571	9 + 10 + 9 + 10

Part Number (Square)	A (mm)	B (mm)	C (mm)	Number Of Rods
ECHQ1515	150	230	230	1 + 2 + 1 + 2
ECHQ2020	200	280	280	2 + 3 + 2 + 3
ECHQ2525	250	330	330	3 + 4 + 3 + 4
ECHQ3030	300	380	380	4 + 5 + 4 + 5
ECHQ3535	350	430	430	5 + 6 + 5 + 6
ECHQ4040	400	480	480	6 + 7 + 6 + 7
ECHQ4545	450	530	530	7 + 8 + 7 + 8
ECHQ5050	500	580	580	8 + 9 + 8 + 9

Other sizes available upon request

At A Glance



Protection: Secondary



Feed Type: Gravity



Material Type: NdFeB



Cleaning Type: Automatic

Our Auto-Shuttle magnetic separator enables screening of processed products 24 hours a day, seven days a week, without the need for manual intervention. The system can even carry out a full clean without the need to stop the process.

The unit is supplied with a pre-programmed PLC that can either work independently or connected to the central control rooms system for remote activation or monitoring etc. There are reed switches fitted to each end of the separator tubes to indicate the position of each magnetic core. The full system remains air tight throughout normal operation making it suitable for environments where ATEX equipment is required.



Benefits

- Fully autonomous in operation
- Removes micron sized contaminants
- Reduces 'spark' risk
- Suitable for control room connection

Performance

Magnetic Performance	7000, 9000 and 10000 Gauss
Performance Reading	On tube surface
Magnet Grade	N35 & N45 – Inspected and confirmed via hysteresigraph prior to use
Temperature	-5°C / +40°C
Pressure	+ / - 0.2 Bar

Suitability

Suitable Products	Dry powders and granulates, flour, sugar and salt
Suitable Location	Any vertical process line

Options

- Pharmaceutical specification
- Siemens, Mitsubishi or Allen Bradley PLC
- Flanged to suit
- Higher temperature versions available
- Metal detectable seal

Materials

Magnetic Material	Rare Earth Neodymium Iron Boron - (NdFeB)
Housing	316 grade stainless steel
Tubing	316 grade stainless steel
Other Parts	316 grade stainless steel
Sealing	Self adhered white foam
Surface Finish	Brushed internally / Polished externally to 1.2µm
PLC	Cruzet

Cleaning

The magnetic cores remain in the process chamber until a cleaning signal is given. Then compressed air is fed into each separator tube forcing the core to the other end of the unit. The contamination follows the core, which first passes through the product return chamber, which prevents loss of good product, and into the cleaning chamber where the collected contamination is deposited. The cleaning chamber is fitted with a transition piece, which allows a collection container to be fitted. It is this container that is removed to assess the collected contamination.

Auto-Shuttle Double Row

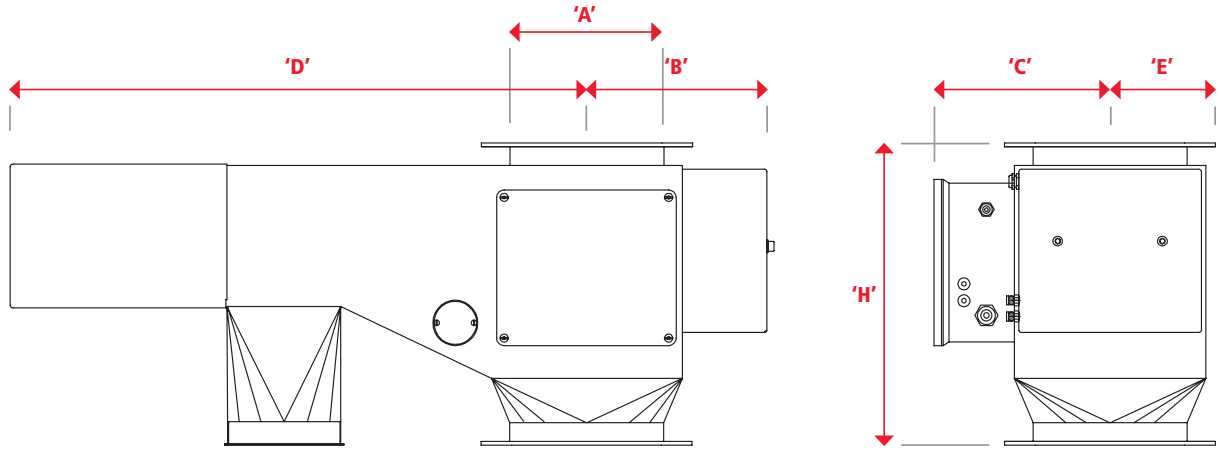

Part Number (Round)	Inlet / Outlet A (mm)	B (mm)	C (mm)	D (mm)	E (mm)	H (mm)	Number Of Rods
ASHD150	150	213	263	787	115	400	3 + 2
ASHD200	200	238	288	837	140	400	3 + 2
ASHD250	250	263	313	887	165	400	4 + 3
ASHD300	300	288	338	937	190	400	5 + 4
ASHD350	350	313	363	987	215	400	6 + 5
ASHD400	400	338	388	1037	240	400	7 + 6
ASHD450	450	363	413	1087	265	400	8 + 7
ASHD500	500	388	438	1137	290	400	9 + 8
ASHD550	550	413	463	1187	315	400	10 + 9
ASHD600	600	438	488	1237	340	400	11 + 10

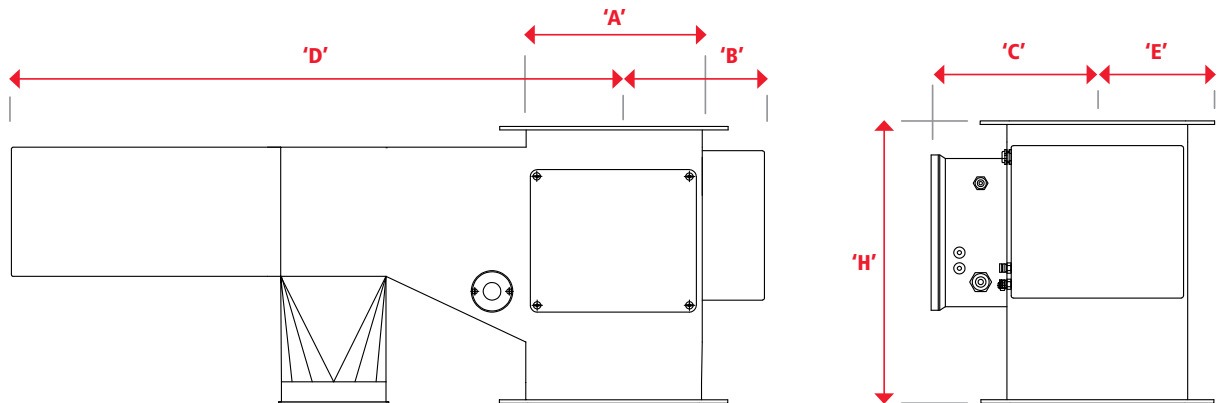

Part Number (Square)	Inlet / Outlet A (mm)	B (mm)	C (mm)	D (mm)	E (mm)	H (mm)	Number Of Rods
ASHD1515	150	185	238	817	115	350	2 + 1
ASHD2020	200	210	263	867	140	350	3 + 2
ASHD2525	250	235	288	917	165	350	4 + 3
ASHD3030	300	260	313	967	190	350	5 + 4
ASHD3535	350	285	338	1017	215	350	6 + 5
ASHD4040	400	310	363	1067	240	350	7 + 6
ASHD4545	450	335	388	1117	265	350	7 + 6
ASHD5050	500	360	413	1167	290	350	8 + 7
ASHD5555	550	385	438	1217	315	350	9 + 8
ASHD6060	600	410	463	1267	340	350	10 + 9

For non-standard sizes, please contact sales@eclipsemagnetics.com

Note: Dimension E is given from the process centreline to the outer edge of the flange

Auto-Shuttle Triple Row

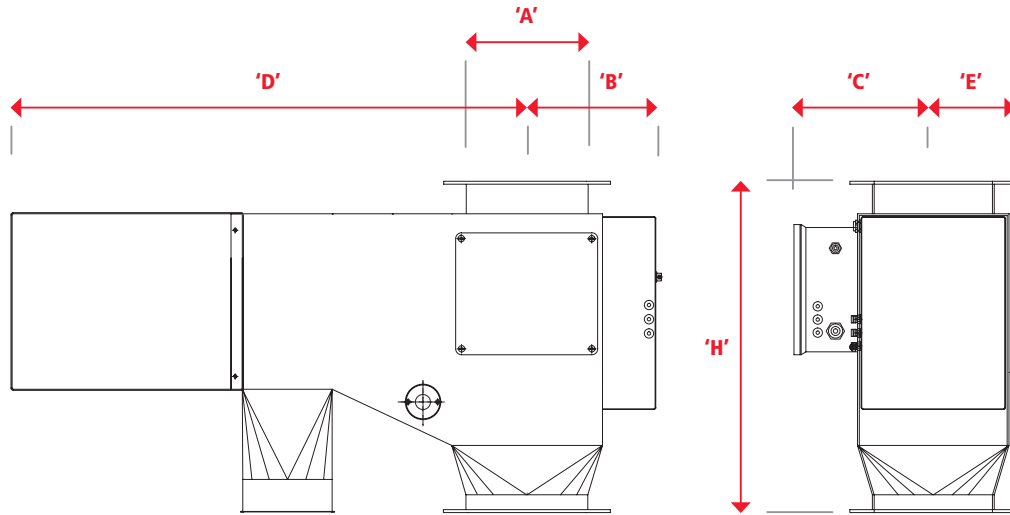

Part Number (Round)	Inlet / Outlet A (mm)	B (mm)	C (mm)	D (mm)	E (mm)	H (mm)	Number Of Rods
ASHT150	150	213	263	787	115	500	2 + 3 + 2
ASHT200	200	238	288	837	140	500	2 + 3 + 2
ASHT250	250	263	313	887	165	500	3 + 4 + 3
ASHT300	300	288	338	937	190	500	4 + 5 + 4
ASHT350	350	313	363	987	215	500	5 + 6 + 5
ASHT400	400	338	338	1037	240	500	6 + 7 + 6
ASHT450	450	363	413	1087	265	500	7 + 8 + 7
ASHT500	500	388	438	1137	290	500	8 + 9 + 8
ASHT550	550	413	463	1187	315	500	9 + 10 + 9
ASHT600	600	438	488	1237	340	500	10 + 11 + 10

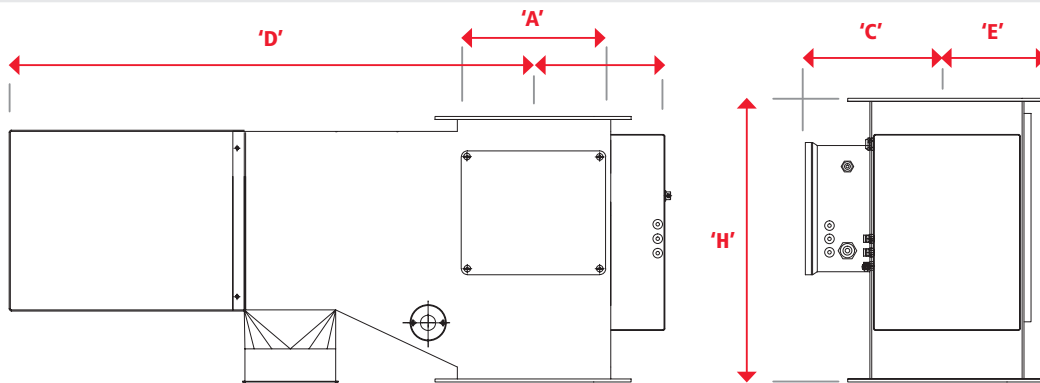

Part Number (Square)	Inlet / Outlet A (mm)	B (mm)	C (mm)	D (mm)	E (mm)	H (mm)	Number Of Rods
ASHT1515	150	185	238	817	115	450	1 + 2 + 1
ASHT2020	200	210	263	867	140	450	2 + 3 + 2
ASHT2525	250	235	288	917	165	450	3 + 4 + 3
ASHT3030	300	260	313	967	190	450	4 + 5 + 4
ASHT3535	350	285	338	1017	215	450	5 + 6 + 5
ASHT4040	400	310	363	1067	240	450	6 + 7 + 6
ASHT4545	450	335	388	1117	265	450	7 + 8 + 7
ASHT5050	500	360	413	1167	290	450	8 + 9 + 8
ASHT5555	550	385	438	1217	315	450	9 + 10 + 9
ASHT6060	600	410	463	1267	340	450	10 + 11 + 10

For non-standard sizes, please contact sales@eclipsemagnetics.com

Note: Dimension E is given from the process centreline to the outer edge of the flange

Auto-Shuttle Quadruple Row

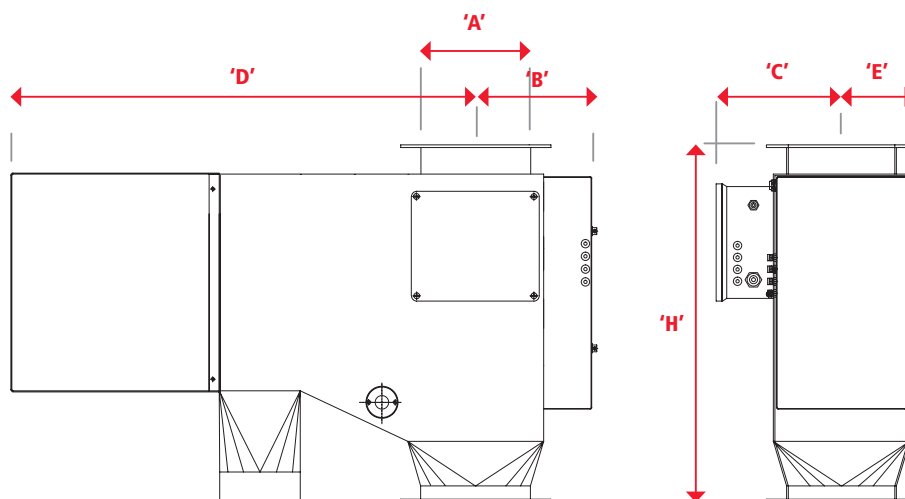

Part Number (Round)	Inlet / Outlet A (mm)	B (mm)	C (mm)	D (mm)	E (mm)	H (mm)	Number Of Rods
ASHQ150	150	213	263	787	115	600	3 + 2 + 3 + 2
ASHQ200	200	238	288	837	140	600	3 + 2 + 3 + 2
ASHQ250	250	263	313	887	165	600	4 + 3 + 4 + 3
ASHQ300	300	288	338	937	190	600	5 + 4 + 5 + 4
ASHQ350	350	313	363	987	215	600	6 + 5 + 6 + 5
ASHQ400	400	338	388	1037	240	600	7 + 6 + 7 + 6
ASHQ450	450	363	413	1087	265	600	8 + 7 + 8 + 7
ASHQ500	500	388	438	1137	290	600	9 + 8 + 9 + 8
ASHQ550	550	413	463	1187	315	600	10 + 9 + 10 + 9
ASHQ600	600	438	488	1237	340	600	11 + 10 + 11 + 10

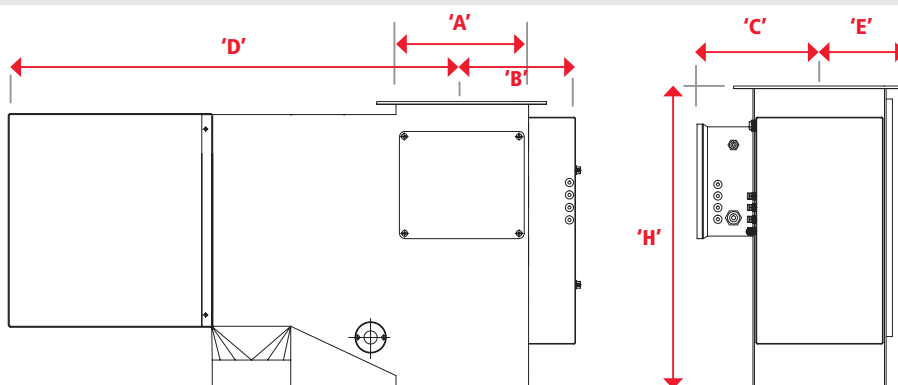

Part Number (Square)	Inlet / Outlet A (mm)	B (mm)	C (mm)	D (mm)	E (mm)	H (mm)	Number Of Rods
ASHQ1515	150	185	238	817	115	550	2 + 1 + 2 + 1
ASHQ2020	200	210	263	867	140	550	3 + 2 + 3 + 2
ASHQ2525	250	235	288	917	165	550	4 + 3 + 4 + 3
ASHQ3030	300	260	313	967	190	550	5 + 4 + 5 + 4
ASHQ3535	350	285	338	1017	215	550	6 + 5 + 6 + 5
ASHQ4040	400	310	363	1067	240	550	7 + 6 + 7 + 6
ASHQ4545	450	335	388	1117	265	550	8 + 7 + 8 + 7
ASHQ5050	500	360	413	1167	290	550	9 + 8 + 9 + 8
ASHQ5555	550	385	438	1217	315	550	10 + 9 + 10 + 9
ASHQ6060	600	410	463	1267	340	550	11 + 10 + 11 + 10

For non-standard sizes, please contact sales@eclipsemagnetics.com

Note: Dimension E is given from the process centreline to the outer edge of the flange

At A Glance

- Protection: Secondary**
- Feed Type: Gravity**
- Material Type: NdFeB**
- Cleaning Type: Manual**

Our high intensity magnetic Rota-Grid separator has been designed specifically to process difficult products that are prone to bridging and/or caking.

The unit contains a centrally mounted magnetic 'rota' assembly: numerous 'easy clean' magnetic rods are arranged in a 'wheel' around and parallel to the axis of rotation. The number of rods used depends on the inlet and outlet size.

The assembly rotates, gently agitating the product being processed. It is this agitation that prevents blockages occurring. All dry and semi-dry powders and granular type materials, such as starch etc., can be processed through the unit. The Rota-Grid can be supplied to the most stringent of standards, such as those required in the pharmaceutical industry.



Benefits

- Easy to clean
- Allows difficult products to be screened
- Reduces 'spark' risk
- Removes sub-micron sized contaminants

Performance

Magnetic Performance	7000, 9000, 10000 (Easy clean), 11000 (Fixed) & 12000 (Fixed) Gauss
Performance Reading	On product contact surface
Magnet Grade	N35 – Inspected and confirmed via hysteresigraph prior to use
Temperature	-20°C / +60°C
Pressure	+ / - 0.2 Bar
Electrical Specification	400v industrial three phase IP65 rated motor gearbox

Suitability

Suitable Products	Dry and semi-dry powders and granulates
Suitable Location	Any vertical process line

Materials

Magnetic Material	Rare Earth Neodymium Iron Boron - (NdFeB)
Housing	316 grade stainless steel
Tubing	316 grade stainless steel
Other Parts	316 grade stainless steel
Sealing	Self adhered white foam
Surface Finish	Brushed internally / Polished externally to 1.2µm

Cleaning

To clean, simply remove the door and remove the assembly from the housing. Remove the magnetic cores from the assembly. All attracted contamination will then be released allowing for inspection or further analysis.

Options

- Metal Detachable seal
- Larger sizes available
- Rota support track system
- Pharmaceutical specification

Rota-Grid

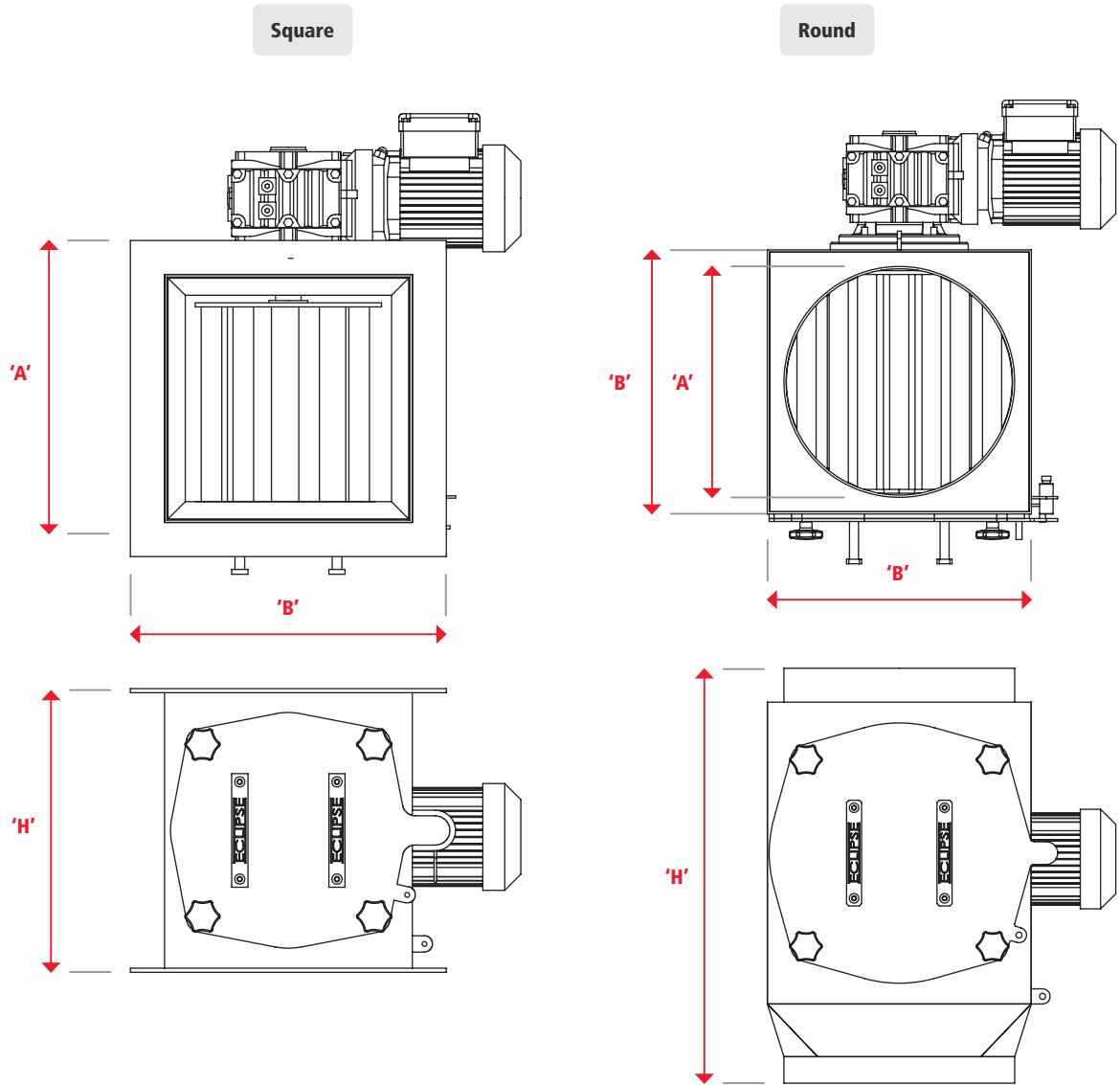

Part Number (Round)	Spout Dia. A(mm)	Width x Depth B (mm)	H (mm)	kW Rating	Number Of Rods	Weight (kg)
RG200	200	250 x 250	450	0.25	6	35
RG250	250	300 x 300	500	0.25	7	44
RG300	300	350 x 350	550	0.25	9	55
RG350	350	400 x 400	600	0.25	10	68
RG400	400	450 x 450	650	0.25	13	82

Part Number (Square)	Spout Size A (mm)	Width x Depth B (mm)	H (mm)	kW Rating	Number Of Rods	Weight (kg)
RG2020	200 x 200	200 x 200	250	0.18	5	26
RG2525	250 x 250	250 x 250	300	0.25	6	33
RG3030	300 x 300	300 x 300	350	0.25	7	43
RG3535	350 x 350	350 x 350	400	0.25	9	54
RG4040	400 x 400	400 x 400	450	0.25	10	67

For non-standard sizes, please contact sales@eclipsemagnetics.com

Auto-Rota Shuttle



At A Glance

- Protection: Secondary
- Feed Type: Gravity
- Material Type: NdFeB
- Cleaning Type: Automatic

Our Auto-Rota Shuttle combines the benefits of our Auto-Shuttle and Rota-Grid unit in one. The Auto-Rota Shuttle enables screening of difficult bridging and or caking products 24/7 without the need for manual intervention.

The system can even carry out a full clean without the need to stop the process, thereby enabling continuous production.

The unit is supplied with a pre-programmed PLC that can either work independently or connected to the central control rooms system for remote activation or monitoring etc. The full system remains air tight throughout normal operation making it suitable for environments where ATEX equipment is required.

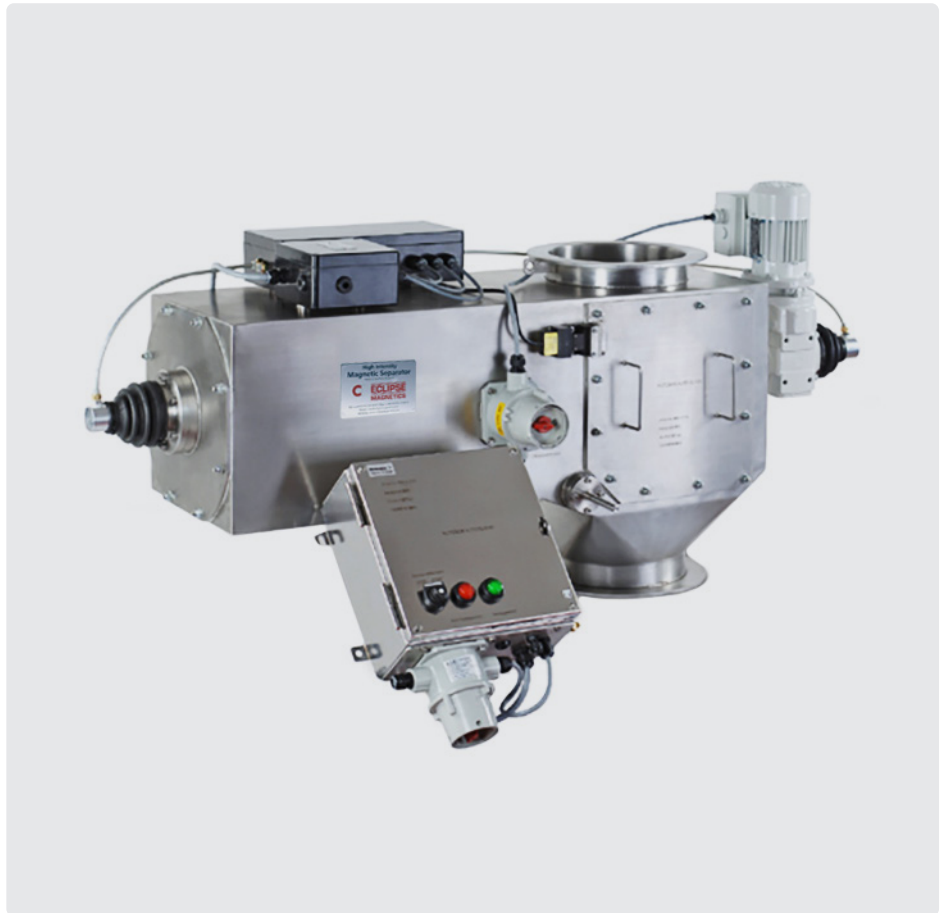

Benefits

- Reduces 'spark' risk
- Fully autonomous in operation
- Suitable for control room connection
- Removes sub-micron sized contaminants

Performance

Magnetic Performance	7000, 9000 and 10000 Gauss
Performance Reading	On tube surface
Magnet Grade	N35 & N45 – Inspected and confirmed via hysteresigraph prior to use
Temperature	-5°C / +40°C
Pressure	+ / - 0.2 Bar

Suitability

Suitable Products	Dry and semi-dry powders and granulates
Suitable Location	Any vertical process line

Materials

Magnetic Material	Rare Earth Neodymium Iron Boron - (NdFeB)
Housing	316 grade stainless steel
Tubing	316 grade stainless steel
Other Parts	316 grade stainless steel
Sealing	Self adhered white foam
Surface Finish	Brushed internally / Polished externally to 1.2µm

Cleaning

The contamination follows the core, first through the product return chamber, which prevents loss of good product, and into the cleaning chamber, where the collected contamination is deposited. The cleaning chamber is fitted with a transition piece, which allows a collection container to be fitted. This container is removed to assess the collected contamination.

Options

- Pharmaceutical specification
- Flanged to suit
- Metal detectable seals
- Siemens, Mitsubishi or Allen Bradley PLC

Auto-Rota Shuttle

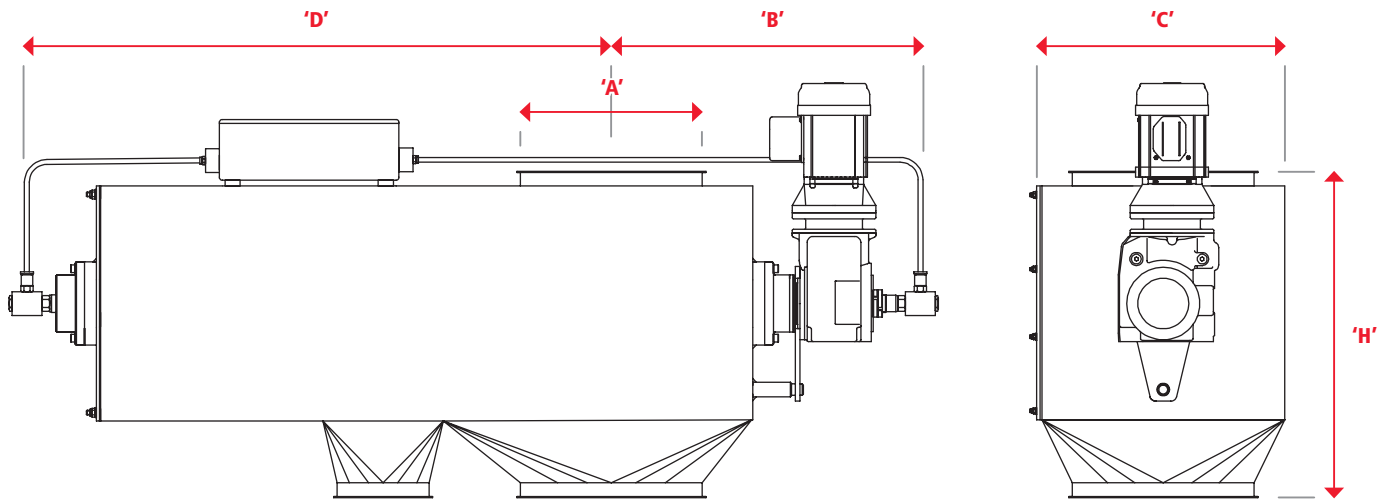

Part Number (Round)	Inlet / Outlet A (mm)	B (mm)	C (mm)	D (mm)	H (mm)	kW Rating	Number Of Rods	Weight (kg)
ARS150	150	475	250	815	400	0.18	5	90
ARS200	200	500	300	915	450	0.18	6	105
ARS250	250	525	350	1015	500	0.18	7	120
ARS300	300	550	400	1115	550	0.18	9	135
ARS350	350	575	450	1215	600	0.25	10	150
ARS400	400	600	500	1315	650	0.25	13	165
ARS450	450	625	550	1415	700	0.25	15	180

Part Number (Square)	Inlet / Outlet A (mm)	B (mm)	C (mm)	D (mm)	H (mm)	kW Rating	Number Of Rods	Weight (kg)
ARS1515	150 x 150	475	250	815	400	0.18	5	88
ARS2020	200 x 200	500	300	915	450	0.18	6	100
ARS2525	250 x 250	525	350	1015	500	0.18	7	112
ARS3030	300 x 300	550	400	1115	550	0.18	9	126
ARS3535	350 x 350	575	450	1215	600	0.25	10	142
ARS4040	400 x 400	600	500	1315	650	0.25	13	155
ARS4545	450 x 450	625	550	1415	700	0.25	15	168

For non-standard sizes, please contact sales@eclipsemagnetics.com

At A Glance



Protection: Secondary



Feed Type: Lean / Dilute Phase



Material Type: NdFeB



Cleaning Type: Manual

Our Pneumag high intensity magnetic separator has been designed to operate in lean / dilute conveying lines to provide protection against ferrous and para-magnetic contamination.

The unit contains a single double row high intensity magnetic cartridge. It is secured into its housing by quick release toggle clamps, which ensure even pressure is generated around the unique silicon-based metal-detectable seal.

The Pneumag can be incorporated into any form of pneumatic conveying line, from lean to dense phase, and can be installed at any angle from vertical to horizontal. A common installation location is at tanker discharge to inspect incoming materials.

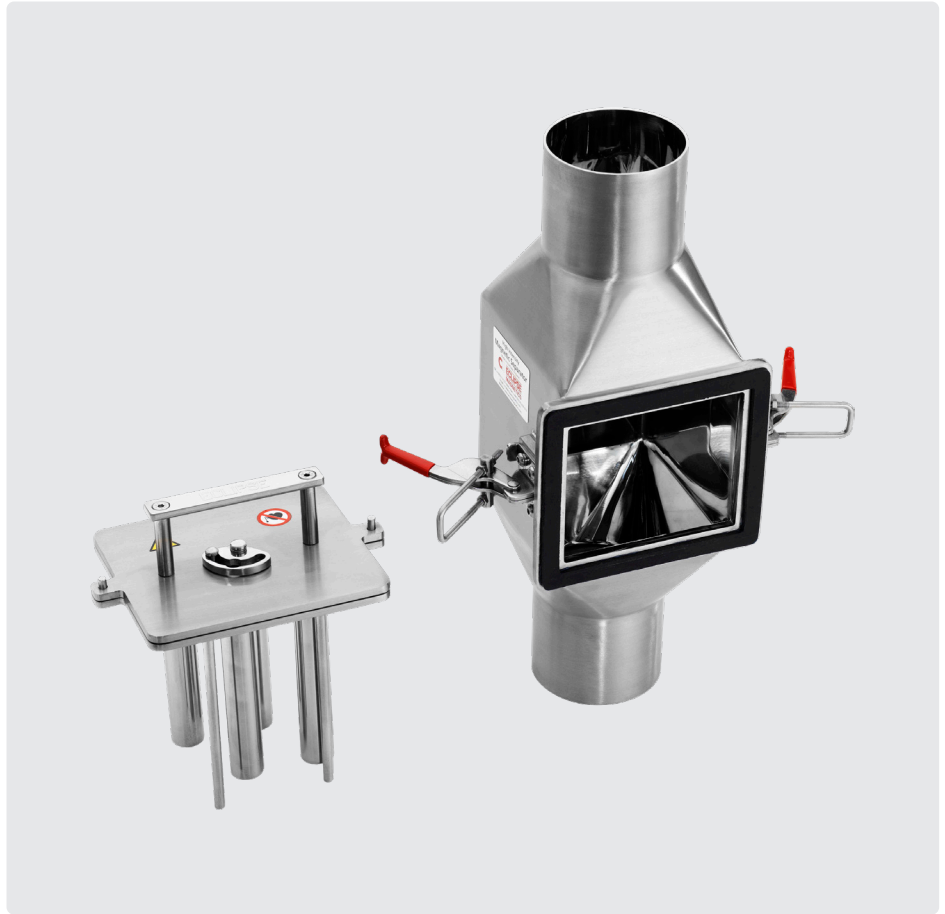

Benefits

- Reduces 'spark' risk
- Metal detectable seal
- Tamper proof guard
- Removes sub-micron sized contaminants

Performance

Magnetic Performance	7000, 9000, 10000 (Easy clean), 11000 (Fixed) & 12000 (Fixed) Gauss
Performance Reading	On tube surface
Magnet Grade	N35 & N45 – Inspected and confirmed via hysteresigraph prior to use
Temperature	-20°C / +60°C
Pressure	+ / - 1 Bar

Suitability

Suitable Products	Dry powders and granulates
Suitable Location	All locations

Materials

Magnetic Material	Rare Earth Neodymium Iron Boron - (NdFeB)
Housing	316 grade stainless steel
Tubing	316 grade stainless steel
Other Parts	316 grade stainless steel
Sealing	Metal detectable silicon rubber – Blue, FDA approved
Surface Finish	Brushed internally / Polished externally to 1.2µm

Cleaning

The Pneumag uses our 'easy clean' system. To clean, simply release the quick release toggle clamps, remove the contaminated cartridge from the housing and then remove the magnetic cores from the tube assembly. All attracted contamination will be released allowing for inspection or further analysis.

Options

- Pharmaceutical specification
- Safety relay switch
- Higher temperature versions available
- Stainless steel toggle clamps
- Higher pressure units available

Pneumag

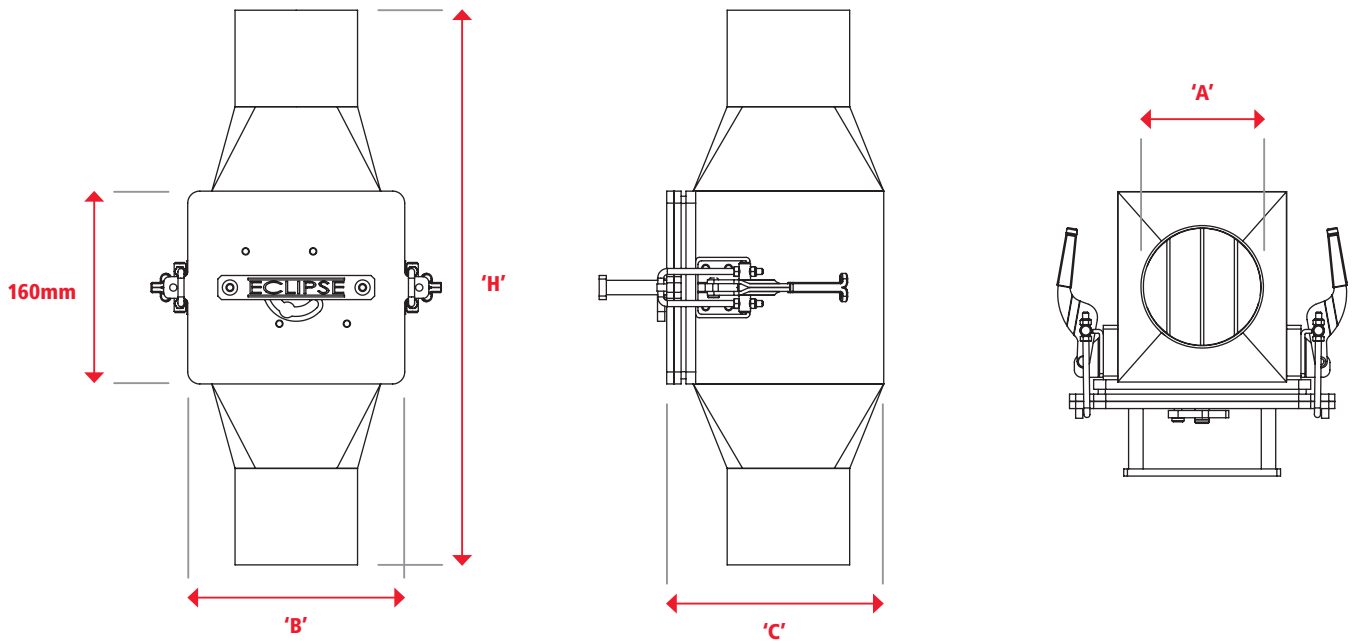

Part Number	A (mm)	B (mm)	C (mm)	H (mm)	Number Of Rods	Weight (kg)
PNEU50	50	150	132	460	3	8
PNEU75	75	180	180	460	4	11
PNEU100	100	180	180	460	4	11
PNEU125	125	240	220	500	6	18
PNEU150	150	240	220	500	6	18
PNEU175	175	290	272	500	8	24
PNEU200	200	290	272	500	8	24

For non-standard sizes, please contact sales@eclipsemagnetics.com

EHEDG EL Class II Magnetic Separator



At A Glance

- Protection:** Secondary
- Feed Type:** Lean / Dilute Phase and gravity discharge
- Material Type:** NdFeb
- Cleaning Type:** Manual

What is EHEDG?

The European Hygienic Engineering & Design Group (EHEDG) is the leading organisation devoted to the advancement of hygienic design and food engineering. Eclipse Magnetics' EHEDG Magnetic Separator successfully conforms to the essential hygienic design guidelines as set out by EHEDG EL Class II, therefore meeting the most demanding hygiene standards and guaranteeing the purity and quality of the finished product.



Our EHEDG EL Class II high intensity magnetic separator has been designed to operate in lean / dilute conveying lines, and gravity pipes to provide protection against ferrous and paramagnetic contamination.

The unit features a double row of magnets on a single assembly high intensity magnetic cartridge. It is secured into its housing by DIN 11853-3 clamps, which ensure even pressure is generated around the O-Ring.

The EHEDG Magnetic Separator can be incorporated into lean/dilute phase, conveying lines and gravity pipes in a vertical orientation. A common installation location is at tanker discharge to inspect incoming raw materials.

Benefits

- Reduces 'spark' risk
- Certified EHEDG Type EL II
- Removes sub-micron sized contaminants

Performance

Magnetic Performance	7,000, 9,000, 10,000 (Easy clean)
Performance Reading	On product contact surface
Magnet Grade	N35 (7k gauss), N45 (9K gauss) & N52 (10k gauss)
Temperature	Standard 80°C
Pressure	+ / - 1 Bar

Suitability

Suitable Products	Dry powders and granulates
Suitable Location	Vertical conveying pipes

Materials

Magnetic Material	Rare Earth Neodymium Iron Boron - (NdFeb)
Housing	*316 grade stainless steel
Tubing	*316 grade stainless steel
Other Parts	*316 grade stainless steel
Sealing	Silicon rubber – Red, FDA approved
Surface Finish	Polished internally Ra 0.6µm Brushed externally to Ra 0.8µm
*316L Available if required	

Cleaning

The EHEDG EL Class II separator uses our 'easy clean' system. To clean, simply release the DIN 11853-3 clamps, remove the contaminated cartridge away from the housing and then remove the magnetic cores from the tube assembly. All attracted contamination will be released allowing for inspection or further analysis.

Options

- Higher temperature versions available
- Seal types - FKM, EPDM, Nitrile
- Plain Spout

EHEDG EL Class II Magnetic Separator

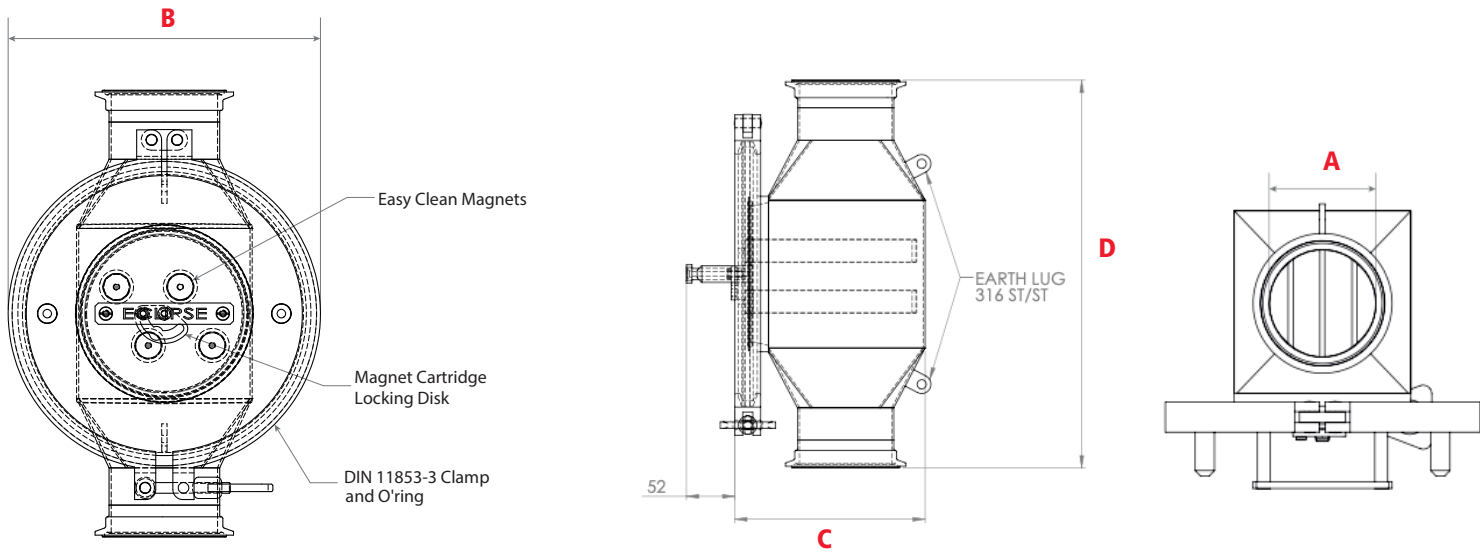

Flanged units DIN11853-3

-XX- Select magnet performance (See table below)

Part Number	A mm	B mm	C mm	D mm	Number of Rods	Weight kg
PNEU65-XX-E-DIN	66	255	192	412	3	14
PNEU80-XX-E-DIN	81	293.5	206	416	4	19
PNEU100-XX-E-DIN	100	293.5	206	416	4	19
PNEU125-XX-E-DIN	125	344.5	239	482	6	27
PNEU150-XX-E-DIN	150	344.5	239	482	6	27

Plain Spouted Units

-XX- Select magnet performance (See table below)

Part Number	A mm	B mm	C mm	D mm	Number of Rods	Weight kg
PNEU65-XX-E-P	66	255	192	412	3	14
PNEU80-XX-E-P	81	293.5	206	416	4	19
PNEU100-XX-E-P	100	293.5	206	416	4	19
PNEU125-XX-E-P	125	344.5	239	482	6	27
PNEU150-XX-E-P	150	344.5	239	482	6	27

Magnet Performance

Select the magnet performance and replace -XX- in the Part Number. High temperature options are available up to 250 °C. With different grade Neodymium and either Silicone or FKM O-Rings.

Code XX	Description	Material	Grade	Gauss	Max Temperature (°C)
SS	Standard Strength	NdFeB	N35	7,000	80°
HS	High Strength	NdFeB	N45	9,000	80°
10K	10,000 Gauss	NdFeB	N52	10,000	80°

At A Glance

- Protection: Secondary**
- Feed Type: Pumped / Liquid Line**
- Material Type: NdFeB**
- Cleaning Type: Manual**

Our high intensity liquid filter magnetic separator has been designed to operate in pressurised transfer lines to provide protection against ferrous and paramagnetic contamination.

The housing comprises a vessel, magnetic lid assembly and band clamp, which secures the unit together. The filter is available in two versions, single wall and double wall (jacketed for heated pipelines).

The filter can be used in any line that processes liquids at all viscosity levels and can be installed at any angle from vertical to horizontal. A common installation location is tanker loading and discharge to inspect outgoing and incoming materials. The filter can be supplied to suit various processing volumes, pressures, temperatures and specifications.



Benefits

- Easy to clean
- Meets audit requirements
- No consumables
- Removes sub-micron sized contaminants

Performance

Magnetic Performance	7000, 9000, 10000, 11000 (Fixed) & 12000 (Fixed) Gauss
Performance Reading	On tube surface
Magnet Grade	N35 & N45 – Inspected and confirmed via hysteresigraph prior to use
Temperature	-20°C / +90°C
Pressure	+ 6.0 Bar

Suitability

Suitable Products	Chocolate, molasses, jam, syrup, juice, sauce, pastes, soup, pickles, spreads, beverages etc.
Suitable Location	All, vertical, horizontal or angled

Materials

Magnetic Material	Rare Earth Neodymium Iron Boron - (NdFeB)
Housing	316 grade stainless steel
Tubing	316 grade stainless steel
Other Parts	304 grade stainless steel
Sealing	Silicon rubber O-ring
Surface Finish	Brushed internally / Polished externally to 1.2µm

Cleaning

To clean, simply release the quick release band clamp, remove the contaminated cartridge from the housing and remove the magnetic cores from the tube assembly. All attracted contamination can be easily removed allowing for inspection or further analysis.

Options

- Pharmaceutical specification
- Overpressure to 30 Bar
- Safety relay switch
- Hygienic Fittings
- Higher temperature versions available

Liquid Filter

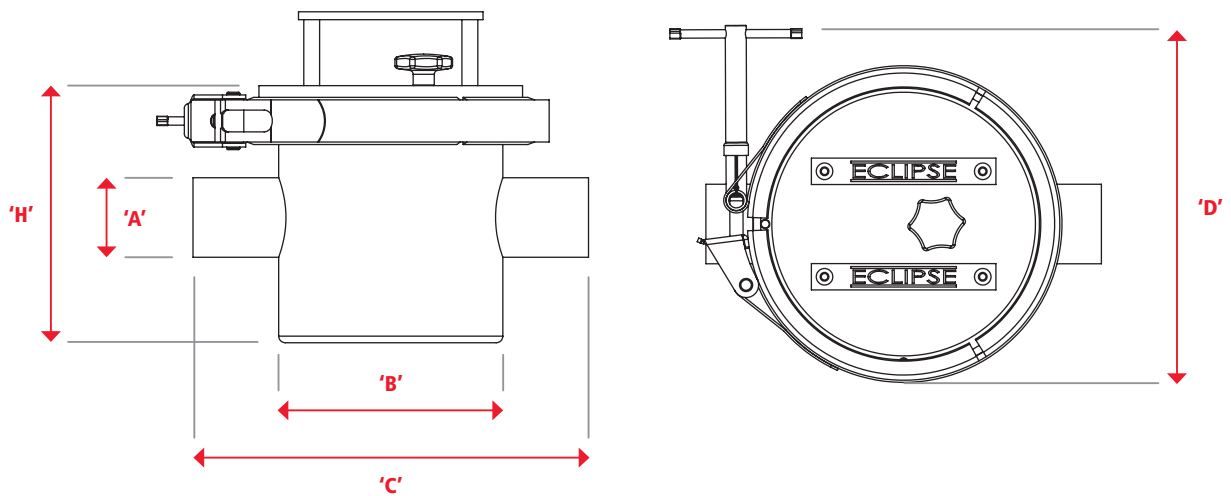

Part Number (Single Wall)	Spout Dia. A (mm)	Dia. B (mm)	C (mm)	D (mm)	H (mm)	Number Of Rods	Weight (kg)
ILF110/38	38						
ILF110/50 (See diagram below)	50	128	250	175	170	3	11
ILF140/50 (See diagram below)	50	146	270	190	190	5	17
ILF200/50	50	170	350	260	200	7	22
ILF200/75	75	170	350	260	200	7	22
ILF300/50	50	260	450	360	300	9	36
ILF300/75	75	260	450	360	300	9	36

Part Number (Jacketed)	Spout Dia. A (mm)	Dia. B (mm)	C (mm)	D (mm)	H (mm)	Number Of Rods	Weight (kg)
ILF200/50/J	50	200	350	260	220	7	22
ILF200/75/J	75	200	350	260	220	7	22
ILF300/50/J	50	300	450	360	300	9	36
ILF300/75/J	75	300	450	360	300	9	36
ILF300/100/J	100	300	450	360	300	9	36

ILF110/50

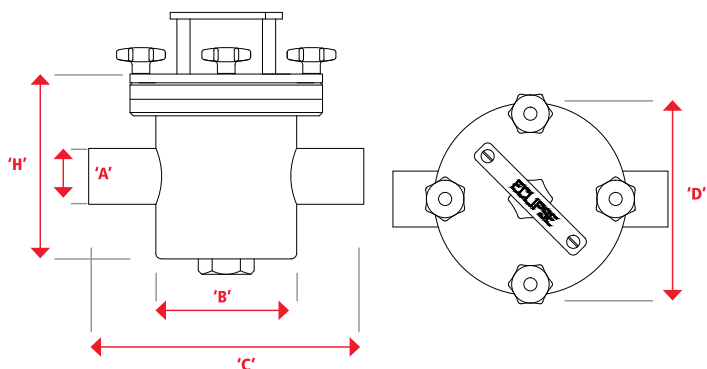

ILF140/50

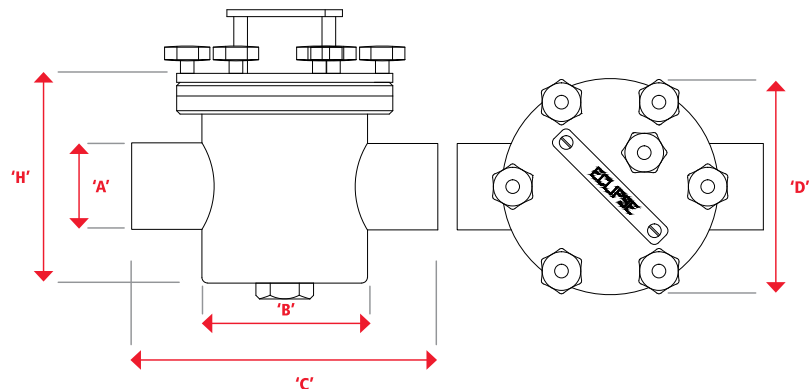

For non-standard sizes, please contact sales@eclipsemagnetics.com

Strip Magnet

At A Glance



Protection: Primary



Feed Type: Conveyor



Material Type: NdFeB



Cleaning Type: Manual

Rare Earth strip magnets are versatile and can be used in various processes. These units are usually installed above transfer conveyors and vibratory feeders to attract 'tramp' type contamination and any loose machinery that has fallen off during the manufacturing or packaging stages.

The unit consists of two rows of magnetic material running the full length of the unit. These generate high intensity magnetic flux fields, which reach approximately 85mm from the units front face. Magnetism is only present on one face ensuring that no surrounding sensitive process machinery is affected. 'Tramp' contamination can be attracted from the conveyor surface even when trapped underneath the product e.g. biscuit etc.



Benefits

- Suitable for wash down
- Easy to clean
- Removes 'tramp' sized contaminants
- High collection capacity
- Rare Earth deep magnetic field

Performance

Magnetic Performance	4,000 Gauss
Performance Reading	On magnetic front face
Magnetic Field Depth	85mm – Using 5mm Ø 25mm long mild steel test piece
Magnet Grade	N35 – Inspected and confirmed via hysteresigraph prior to use
Temperature	-20°C / +90°C

Suitability

Suitable Products	All conveyed products less than 85mm thick
Suitable Location	Above transfer belt conveyors and vibratory feeders

Materials

Magnetic Material	Rare Earth Neodymium Iron Boron - (NdFeB)
Housing	304 grade stainless steel
Surface Finish	Brushed

Cleaning

The strip magnet is highly visible once installed and any attracted contamination can be easily seen. In most cases this contamination can be removed by hand. In high collection installations a simple scraper can be used. Working with the maintenance department, any attracted machinery parts can be quickly identified and corrective maintenance carried out.

Options

- Pharmaceutical specification
- Ceramic magnetic material
- 150mm wide units available
- Length up to 2000mm long
- 316 grade stainless steel
- Higher temperature versions available

Strip Magnet

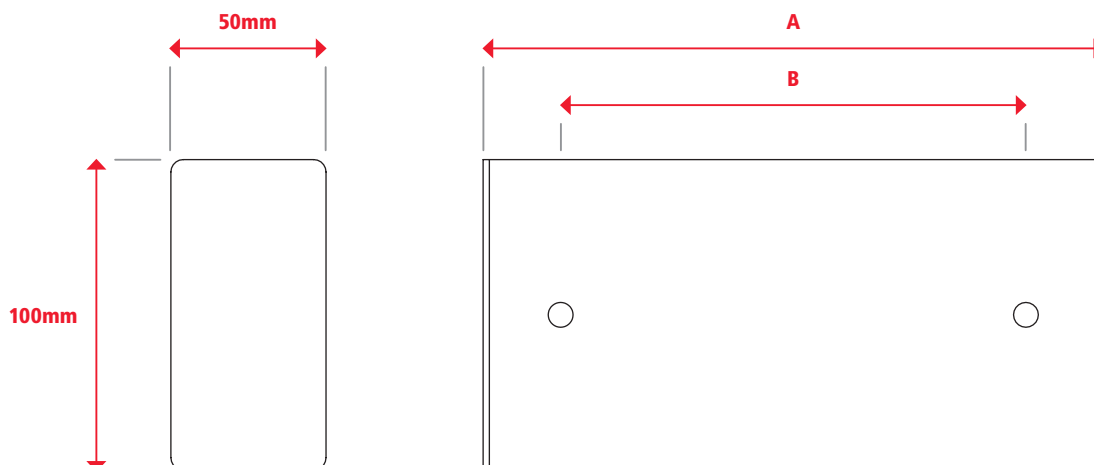

Part Number	A (mm)	B (mm)	Number of Holes	Weight (kg)
SMN100	100	50	2	2.5
SMN200	200	150	2	5.0
SMN300	300	200	2	7.5
SMN400	400	200	2	10
SMN500	500	200	3	12.5
SMN600	600	200	3	15
SMN700	700	200	4	17.5
SMN800	800	200	4	20
SMN900	900	200	5	22.5
SMN1000	1000	200	5	25

For non-standard sizes, please contact sales@eclipsemagnetics.com

Underflow Magnet



At A Glance

- Protection: Primary
- Feed Type: Inclined Chute
- Material Type: NdFeB
- Cleaning Type: Manual

Our high intensity underflow magnet has been designed to operate in arduous conditions and where contamination size is relatively large e.g. nuts, bolts etc. The unit incorporates two magnetic poles which generate high intensity magnetic fields.

The unit is secured to the chute by a hinge and toggle clamp arrangement. The toggle clamps ensure even pressure is generated around the seal to prevent any product leakage.

The underflow magnet can be incorporated into any form of angled pipe or chute section. A common installation location is raw material inlet points for products such as grain, rice, corn, bran and animal feed etc. Two catchment areas ensure that attracted contamination cannot be 'washed off'.



Benefits

- Easy to clean
- Reduces 'spark' risk
- Meets audit requirements
- High collection capacity
- Maintains full flow
- Removes 'tramp' sized contaminants
- Rare Earth deep magnetic field

Performance

Magnetic Performance	3,500 Gauss
Performance Reading	On magnetic front face
Magnet Grade	N35 – Inspected and confirmed via hysteresigraph prior to use
Temperature	-20°C / +90°C
Depth of field	90mm

Suitability

Suitable Products	Dry and semi dry powders, granulates and lumps etc
Suitable Location	All angled chute sections

Materials

Magnetic Material	Rare Earth Neodymium Iron Boron - (NdFeB)
Housing	316 grade stainless steel
Other Parts	316 grade stainless steel
Hinge	304 grade stainless steel
Toggle Clamps	Zinc plated mild steel
Surface Finish	Brushed to 2.4µm

Cleaning

Underflow magnets are very easy to clean. Simply release the two securing toggle clamps and allow the magnet to swing away under its own weight, this will give access to the magnetic face. All attracted contamination can now be removed by a gloved hand or scraper tool.

Options

- Pharmaceutical specification
- Ceramic magnetic material
- Higher temperature versions available
- Higher gauss versions available
- Sizes up to 800mm long
- 304 grade stainless steel

Underflow Magnet

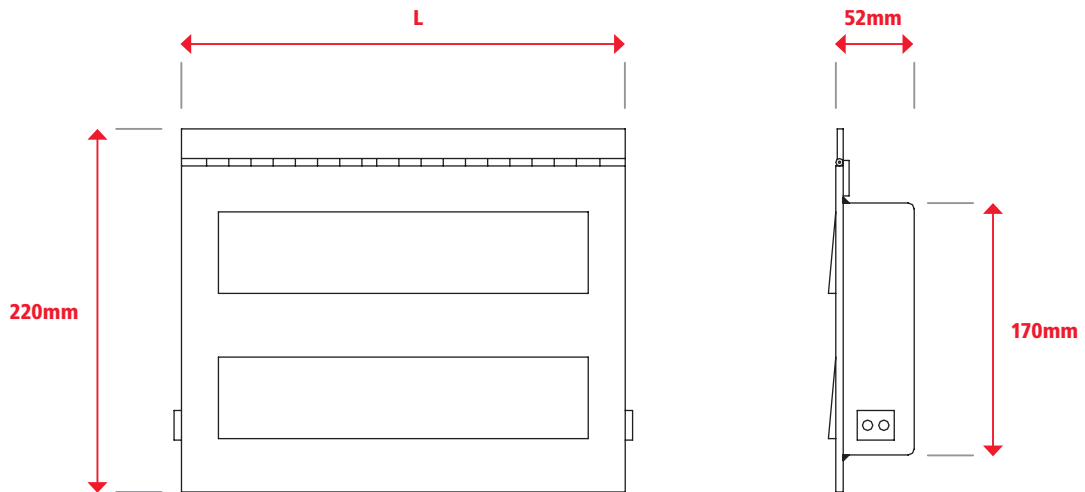

Part Number	L (mm)	Weight (kg)
UFM200	200	10
UFM250	250	13
UFM300	300	15
UFM350	350	17
UFM400	400	20
UFM450	450	23
UFM500	500	27

For non-standard sizes, please contact sales@eclipsemagnetics.com

Housed Underflow Magnet

At A Glance



Protection: Primary



Feed Type: Inclined Chute



Material Type: NdFeB



Cleaning Type: Manual

The housed underflow magnet is available with a single or double underflow magnet array. They are suitable for installation into vertical, horizontal and inclined gravity feed chutes.

Our high intensity underflow magnet has been designed to operate in arduous conditions and where contamination size is relatively large e.g. nuts, bolts etc. The unit incorporates two magnetic poles which generate high intensity magnetic fields. The unit is secured to the chute by a hinge and toggle clamp arrangement which ensure even pressure is generated around the seal to prevent any product leakage.

The housed underflow magnet can be incorporated into any form of angled pipe or chute section. A common installation location is raw material inlet points for products such as grain, rice, corn, bran and animal feed etc.

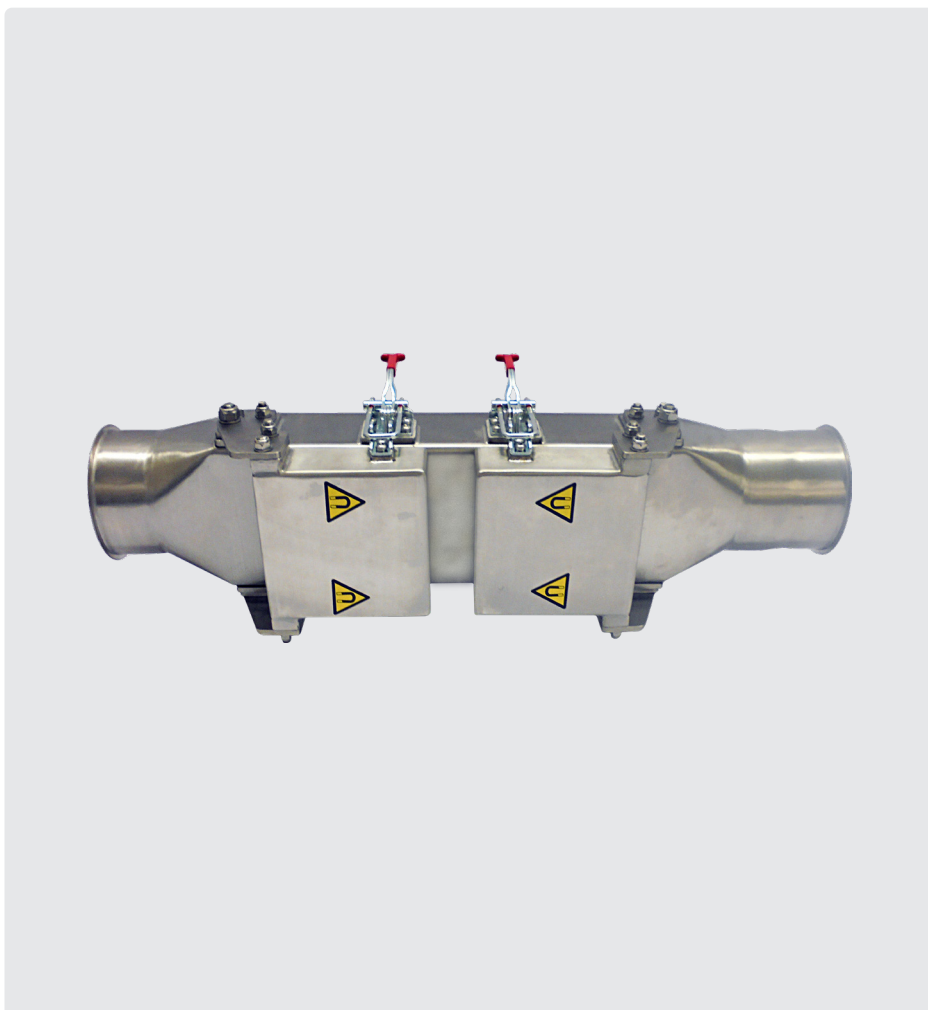

Benefits

- Easy to clean
- Reduces 'spark' risk
- Meets audit requirements
- Maintains full flow
- Removes 'tramp' sized contaminants
- Rare Earth deep magnetic field

Performance

Magnetic Performance	3,500 Gauss
Performance Reading	On magnetic front face
Magnet Grade	N35 – Inspected and confirmed prior to use
Temperature	-20°C / +90°C
Depth of Field	90mm

Suitability

Suitable Products	Dry and semi dry powders, granulates and lumps etc
Suitable Location	All angled chute sections

Materials

Magnetic Material	Rare Earth Neodymium Iron Boron - (NdFeB)
Housing	316 grade stainless steel
Other Parts	316 grade stainless steel
Hinge	304 grade stainless steel
Toggle Clamps	Zinc plated mild steel
Surface Finish	Brushed to 2.4µm

Cleaning

Underflow magnets are very easy to clean. Simply release the two securing toggle clamps and allow the magnet to swing away under its own weight, this will give access to the magnetic face. All attracted contamination can now be removed by a gloved hand or scraper tool.

Options

- Pharmaceutical specification
- Ceramic magnetic material
- Higher temperature versions available
- Sizes up to 2000mm long
- Higher gauss versions available

Housed Underflow Magnet

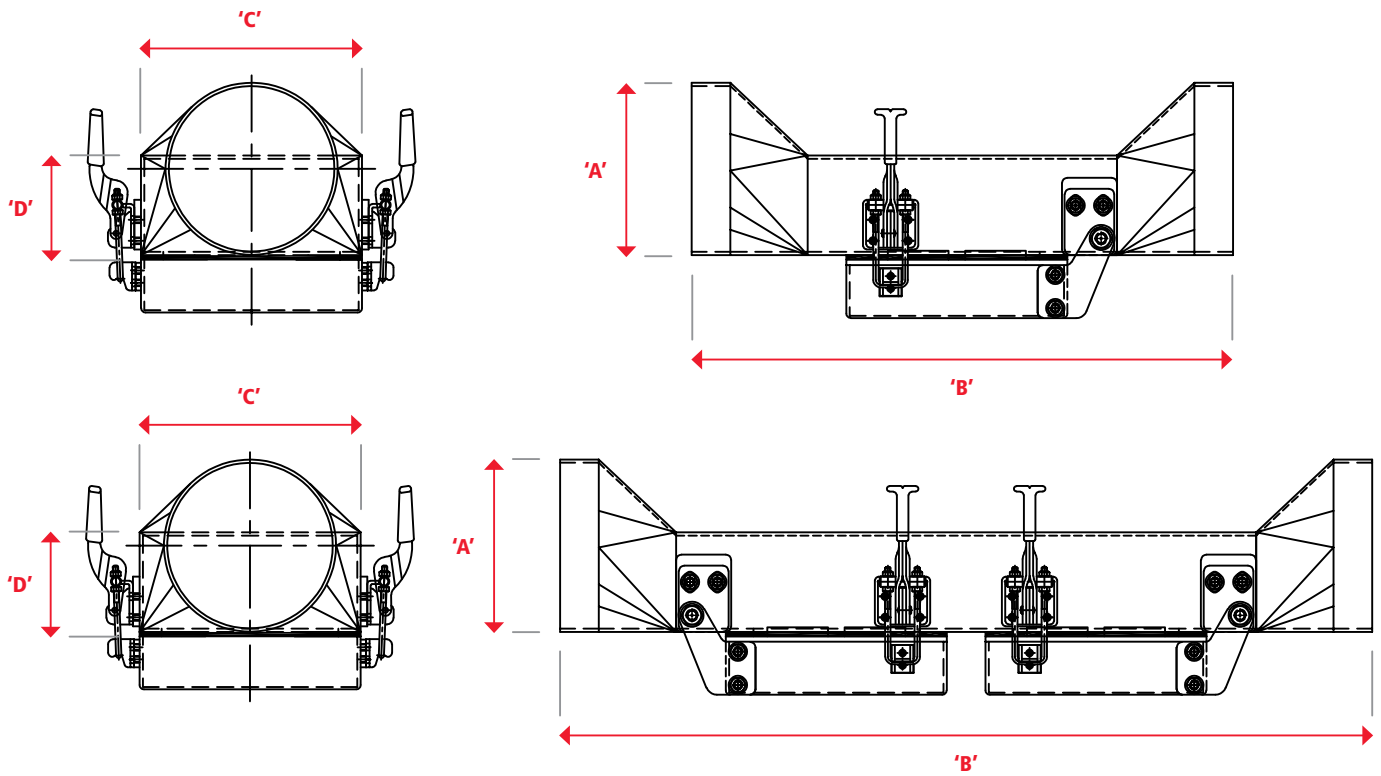

Part Number (Single)	Inlet / Outlet A (mm / inch)	Length B (mm)	Width C (mm)	Thickness D (mm)
HUFS/50	50 / 2	440	150	90
HUFS/75	75 / 3	440	150	90
HUFS/100	100 / 4	440	150	90
HUFS/125	125 / 5	490	200	90
HUFS/150	150 / 6	490	200	90
HUFS/200	200 / 8	540	250	125

Part Number (Double)	Inlet / Outlet A (mm / inch)	Length B (mm)	Width C (mm)	Thickness D (mm)
HUFD/50	50 / 2	635	150	90
HUFD/75	75 / 3	635	150	90
HUFD/100	100 / 4	635	150	90
HUFD/125	125 / 5	735	200	90
HUFD/150	150 / 6	735	200	90
HUFD/200	200 / 8	835	250	125

Bullet Magnet

At A Glance



Protection: Primary



Feed Type:
Gravity / Lean / Dilute Phase



Material Type: NdFeB



Cleaning Type: Manual

Housed bullet magnets are ideal for the removal of tramp type contamination, for example nuts, bolts, staples etc., from gravity and pneumatically conveyed pipelines.

The unit is designed to prevent tramp iron from damaging expensive process machinery such as blenders, granulators, mixers and screw feed conveyors. A high intensity magnetic bullet element is centrally mounted within a stainless steel housing. The design ensures that product flow is unaffected by the magnetic element.

The bullet element incorporates high intensity Rare Earth magnetic material which generates deep penetrating magnetic flux fields ensuring contamination is captured.

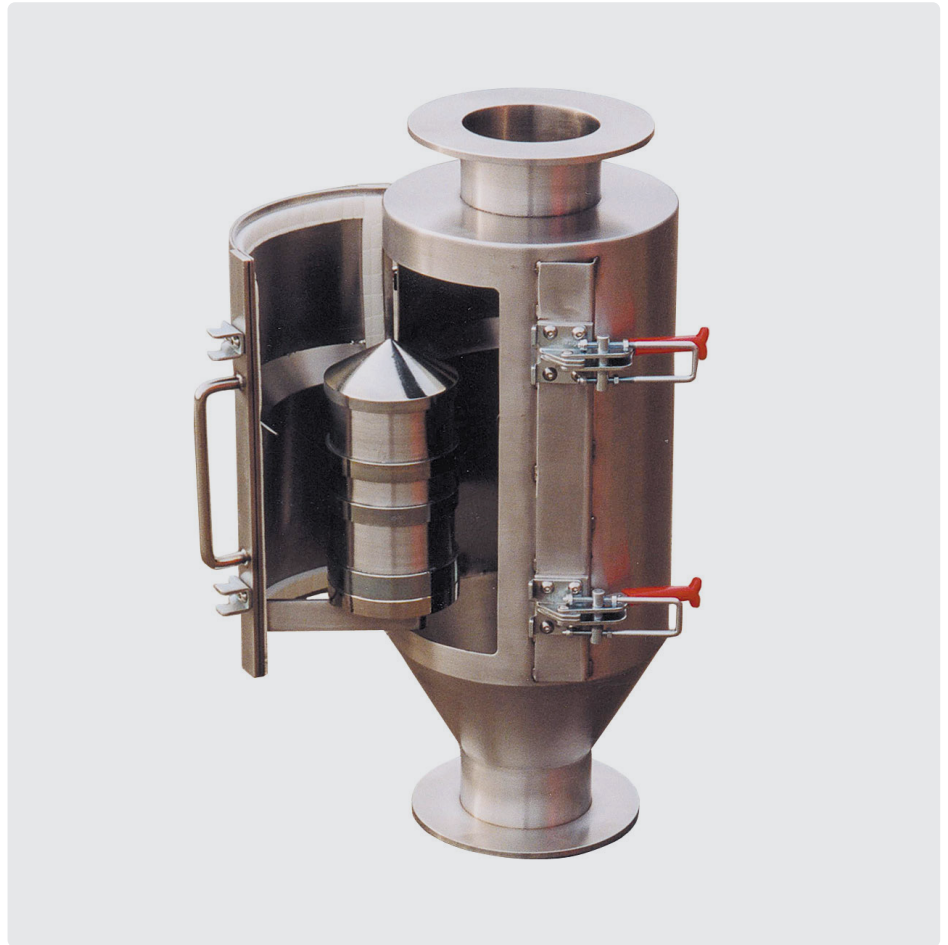

Benefits

- Easy to inspect
- High collection capacity
- Rare Earth deep magnetic field
- Maintains full flow
- Reduces 'spark' risk
- Removes 'tramp' sized contaminants

Performance

Magnetic Performance	9000 Gauss
Performance Reading	On magnetic pole face
Magnet Grade	N45 – Inspected and confirmed via hysteresigraph prior to use
Temperature	-20°C / +90°C
Pressure	+ / - 0.8 Bar

Suitability

Suitable Products	Dry and semi dry powders, granulates and lumps etc
Suitable Location	Inlet / outlet points

Materials

Magnetic Material	Rare Earth Neodymium Iron Boron - (NdFeB)
Housing	304 grade stainless steel
Other Parts	304 grade stainless steel
Toggle Clamps	Zinc plated mild steel
Sealing	Self adhered white foam (FDA)
Surface Finish	Bead blast

Cleaning

The bullet magnet is cleaned by hand. Simply release the door securing toggle clamps and open the door to gain access to the bullet element. All attracted contamination can now be removed. It is advisable to wear protective gloves to avoid any injuries from sharp attracted items.

Options

- Sizes up to 500mm Ø
- 316 grade stainless steel
- Metal detectable silicon rubber seal – dark blue, FDA approved
- Stainless steel toggle clamps

Bullet Magnet

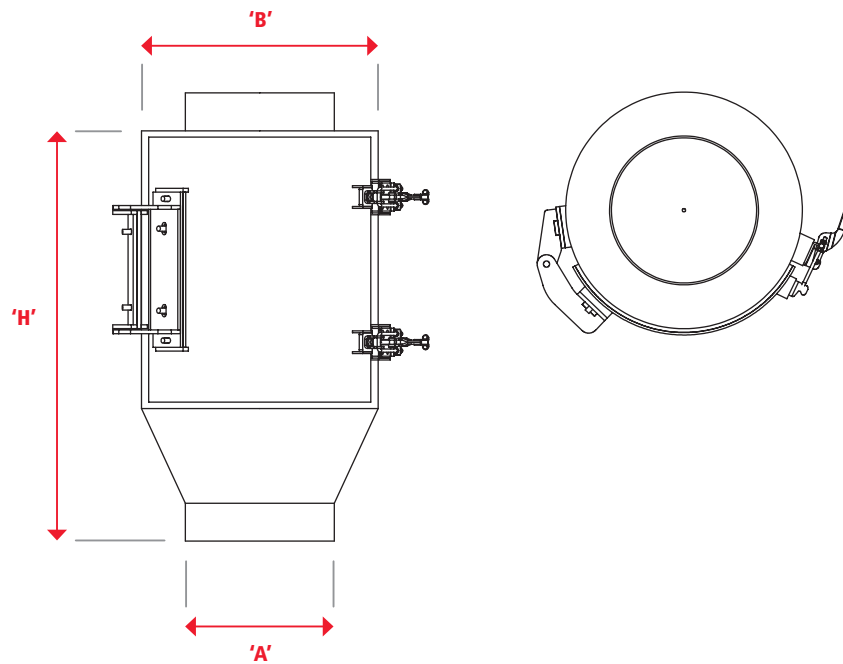

Part Number (Single)	Inlet / Outlet A (mm)	Dia. B (mm)	Height H (mm)	Weight (kg)
HBM075	75	200	490	16
HBM100	100	225	490	22
HBM125	125	250	550	33
HBM150	150	275	550	46
HBM175	175	300	640	60
HBM200	200	325	640	105
HBM250	250	375	710	160
HBM300	300	425	710	210

For non-standard sizes, please contact sales@eclipsemagnetics.com

Chute Magnet



At A Glance



Protection: Primary



Feed Type: Gravity



Material Type: NdFeB



Cleaning Type: Manual

Our high intensity magnetic chute magnet has been designed to operate in arduous conditions and where contamination size is relatively large e.g. nuts, bolts etc.

The unit has two hinged, high intensity magnetic packs, which are secured to a housing by an adjustable hinge arrangement and tri-cone locking nut. These tri-cone nuts ensure even pressure is generated around the food grade silicon seal.

The chute magnet can be incorporated into any form of vertical or angled pipe or chute section. A common installation location is raw material inlet points for products such as grain, rice, corn, bran and animal feed etc. A central diverter is mounted on the inlet. This directs processed product onto the magnetic face ensuring a high contamination removal rate.



Benefits

- Easy to clean
- Reduces 'spark' risk
- Rare Earth deep magnetic field
- High collection capacity
- Meets audit requirements
- Removes 'tramp' sized contaminants

Performance

Magnetic Performance	3,500 Gauss
Performance Reading	On magnetic pack face
Magnet Grade	N35 – Inspected and confirmed via hysteresigraph prior to use
Temperature	-20°C / +90°C
Pressure	+ / - 0.2 Bar

Suitability

Suitable Products	Dry powders and granulates
Suitable Location	Inlet / outlet points

Materials

Magnetic Material	Rare Earth Neodymium Iron Boron - (NdFeB)
Housing	304 grade stainless steel
Other Parts	304 grade stainless steel
Toggle Clamps	Stainless Steel
Sealing	Self adhered white foam (FDA)
Surface Finish	Bead Blasted

Cleaning

The chute magnet uses our 'easy clean' system. Simply release the quick-release toggle clamps, swing the packs away from the line and hinge the easy clean plates away. The collected contamination will be free from magnetic attraction and can be simply and easily removed allowing for inspection or further analysis.

Options

- Overpressure to + / - 5 Bar
- Pharmaceutical specification
- Metal detectable silicon rubber seal – dark blue, FDA approved
- Higher gauss versions available
- Sizes up to 500mm Ø or square
- ATEX certified

Chute Magnet

Round

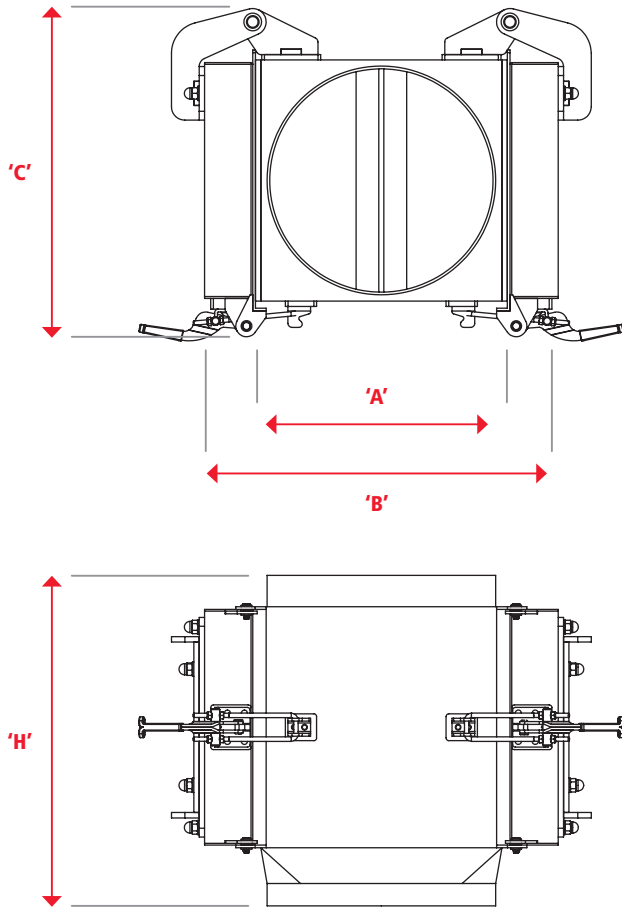

Square

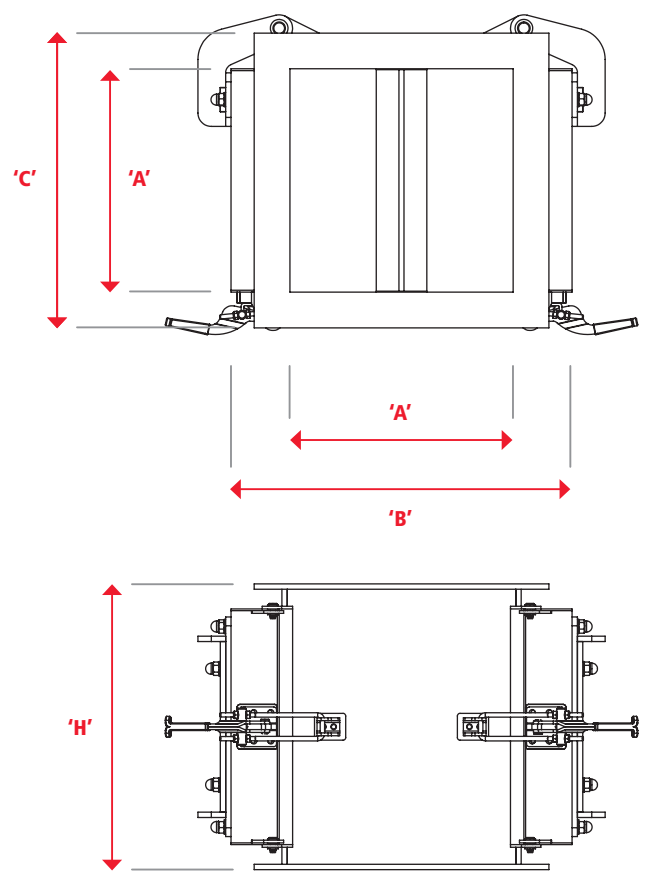

Part Number (Round)	Inlet / Outlet A (mm)	B (mm)	C (mm)	H (mm)	Weight (kg)
CMN150	150	350	250	270	24
CMN200	200	400	300	270	32
CMN250	250	500	380	370	42
CMN300	300	550	420	370	56
CMN350	350	600	470	370	76

Part Number (Square)	Inlet / Outlet A (mm)	B (mm)	C (mm)	H (mm)	Weight (kg)
CMN1515	150 x 150	280	230	220	22
CMN2020	200 x 200	330	280	220	30
CMN2525	250 x 250	380	330	320	39
CMN3030	300 x 300	450	380	320	52
CMN3535	350 x 350	480	430	350	72

For non-standard sizes, please contact sales@eclipsemagnetics.com

Drum Magnet

At A Glance



Protection: Primary



Feed Type: Conveyor



Material Type: NdFeB



Cleaning Type: Automatic

Our high intensity drum magnet is ideal for the continuous removal of tramp ferrous contamination from any dry bulk material and is regularly installed in the most arduous of environments.

Drums should be fitted at the discharge end of conveyors or vibratory feeders. High performance Rare Earth magnets are incorporated within a stainless steel wear resistant drum shell. Cleaning is continuous: the drum rotates taking contamination away from the static magnets.

Units are available for all product volume flows ranging from 5–500m³ / hr and a contamination loading of up to 50% of the total product volume.



Benefits

- Reduces spark risk
- Continuous self cleaning
- Removes large to medium sized contamination
- Allows difficult products to be screened
- High volume capacity

Performance

Magnetic Performance	3,500 Gauss
Magnetic field depth	215mm Dia. = 85mm, 315mm Dia. = 100mm 400mm Dia. = 150mm*
Temperature	-5°C / +40°C

Suitability

Suitable Products	Dry powders, granulates, grain and sand etc.
Suitable Location	End of conveyor belt, vibratory feeder or in-line chute sections

Materials

Magnetic Material	Rare Earth Neodymium Iron Boron - (NdFeB)
Drum Shell	304 grade stainless steel

Cleaning

As the drum rotates, carry-over fins move the contamination to the rear of the drum where the magnetic area ends where the contamination falls in the opposite direction of the material being processed. The drum rotates at between 20–25 RPM ensuring that even the most heavily contaminated product can be separated.

Options

- 316 grade stainless steel
- Replaceable wear skin
- ATEX certified
- Higher temperature versions available

*Mild steel test piece Ø 5mm x 25mm long

Drum Magnet

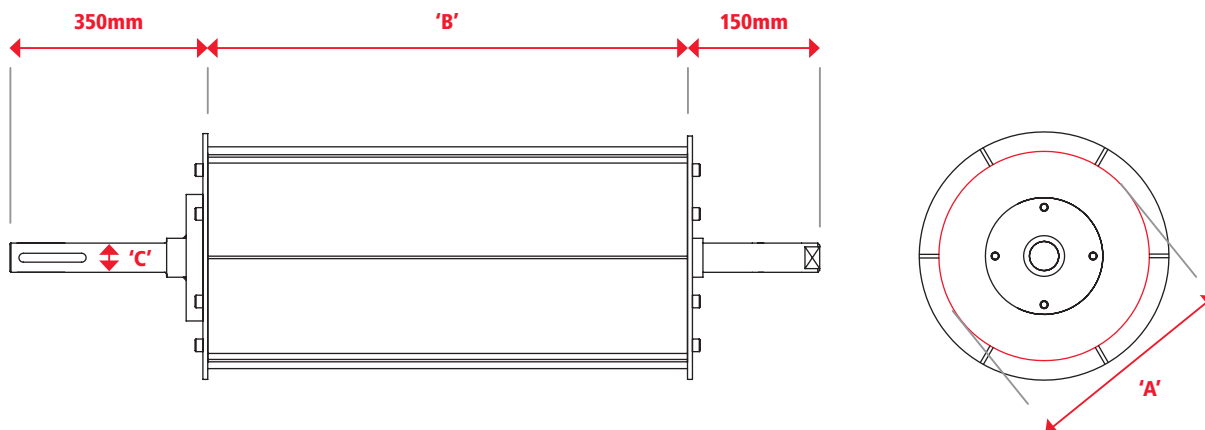

Part Number	Diameter A (mm)	B (mm)	Diameter C (mm)	Weight (kg)
DMN2140	215	400	30	60
DMN2150	215	500	30	72
DMN2160	215	600	30	84
DMN2170	215	700	30	96
DMN2180	215	800	30	108
DMN2190	215	900	30	120
DMN21100	215	1000	40	132
DMN3140	315	400	40	82
DMN3150	315	500	40	84
DMN3160	315	600	40	108
DMN3170	315	700	40	122
DMN3180	315	800	40	136
DMN3190	315	900	40	150
DMN31100	315	1000	40	154
DMN4040	400	400	50	125
DMN4050	400	500	50	140
DMN4060	400	600	50	155
DMN4070	400	700	50	170
DMN4080	400	800	50	185
DMN4090	400	900	50	200
DMN40100	400	1000	50	215

For non-standard sizes, please contact sales@eclipsemagnetics.com

Housed Drum Magnet

At A Glance



Protection: Primary



Feed Type: Conveyor



Material Type: NdFeB



Cleaning Type: Automatic

Our high intensity housed drum magnet is ideal for the continuous removal of tramp ferrous contamination from any dry bulk material. It is regularly installed in the most arduous of environments.

Housed drums should be fitted at the discharge end of conveyors, vibratory feeders or in-line chute sections.

High performance Rare Earth magnets are contained within a stainless steel wear-resistant drum shell.

Cleaning is continuous: the drum rotates taking contamination away from the static magnets.



Benefits

- Reduces spark risk
- Allows difficult products to be screened
- Continuous self cleaning
- High volume capacity
- Removes large to medium sized contamination

Performance

Magnetic Performance	3,500 Gauss
Magnetic field depth	215mm Dia. = 85mm, 315mm Dia. = 100mm 400mm Dia. = 150mm*
Electrical Spec	400 Volts industrial three phase IP54 rated motor gearbox
Temperature	-5°C / +40°C

Suitability

Suitable Products	Dry powders, granulates, grain and sand etc.
Suitable Location	End of conveyor belt, vibratory feeder or in-line chute sections

Materials

Magnetic Material	Rare Earth Neodymium Iron Boron - (NdFeB)
Drum Shell	304 grade stainless steel
Sealing	Self adhered white foam (FDA)
Surface Finish	Brushed

Cleaning

As the drum rotates, carry-over fins move the contamination to the rear of the drum, where the magnetic area ends, and out of the magnetic field. It then falls through the reject chute section of the housing. The drum rotates at between 20–25 RPM ensuring that even the most heavily contaminated product can be separated.

Options

- 316 grade stainless steel
- Higher temperature versions available

*Mild steel test piece Ø 5mm x 25mm long

Housed Drum Magnet

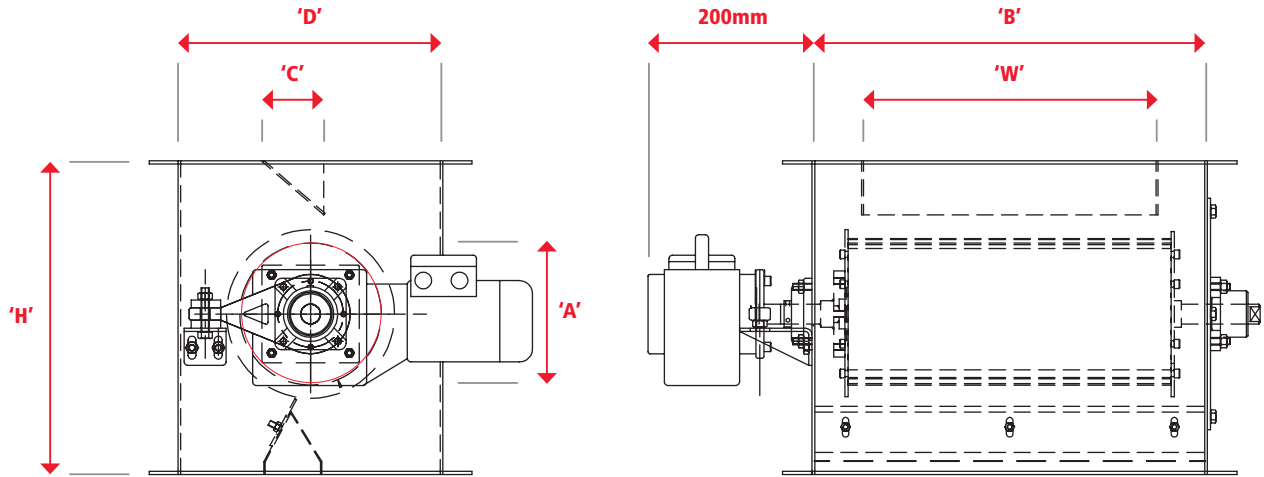

Part Number	Diameter A (mm)	B (mm)	Dia. C (mm)	D (mm)	W (mm)	H (mm)	Weight (kg)
HDMN2140	215	500	75	400	350	475	125
HDMN2150	215	600	75	400	450	475	135
HDMN2160	215	700	75	400	550	475	150
HDMN2170	215	800	75	400	650	475	165
HDMN2180	215	900	75	400	750	475	185
HDMN2190	215	1000	75	400	850	475	210
HDMN21100	215	1100	75	400	950	475	235
HDMN3140	315	500	125	500	350	650	150
HDMN3150	315	600	125	500	450	650	160
HDMN3160	315	700	125	500	550	650	175
HDMN3170	315	800	125	500	650	650	200
HDMN3180	315	900	125	500	750	650	220
HDMN3190	315	1000	125	500	850	650	245
HDMN31100	315	1100	125	500	950	650	275
HDMN4040	400	500	175	585	350	750	185
HDMN4050	400	600	175	585	450	750	205
HDMN4060	400	700	175	585	550	750	220
HDMN4070	400	800	175	585	650	750	240
HDMN4080	400	900	175	585	750	750	265
HDMN4090	400	1000	175	585	850	750	290
HDMN40100	400	1100	175	585	950	750	315

For non-standard sizes, please contact sales@eclipsemagnetics.com

Permanent Magnet Head Roller

At A Glance



Protection: Primary



Feed Type: Conveyor



Material Type: NdFeB



Cleaning Type: Automatic

Installed at the discharge end of flat or troughed belt conveyors, permanent magnetic head rollers are designed to remove tramp iron that cannot be removed by either a plate or overband magnet because of the conveyed product depth.

For the best possible protection against tramp metals use permanent magnetic head rollers in conjunction with plate or overband magnets.

Permanent magnetic head rollers are available in two magnetic materials: standard strength, which uses ceramic magnetic material; and high strength, which uses high intensity Rare Earth magnetic material. The latter is the most popular due to its high contamination removal efficiency.

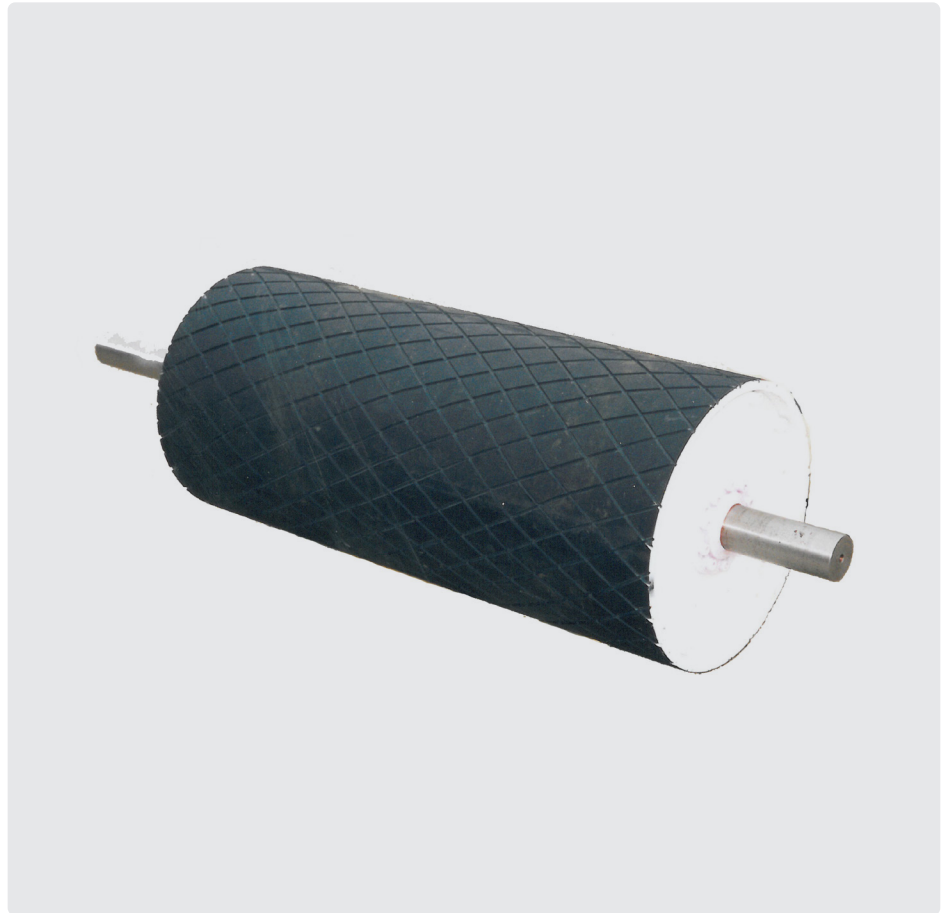

Benefits

- No running costs
- High volume capacity
- Removes large to medium sized contamination
- Allows difficult products to be screened
- Designed for 24 / 7 operation

Performance

Magnetic Performance	3,000 Gauss
Performance reading	On roller surface*
Magnetic field depth	200 Series = 75mm*, 300 Series = 100mm* 400 Series = 125mm*
Temperature	-40°C / +80°C

Suitability

Suitable Products	All conveyable products, wood chip, biomass, recyclables, aggregates, coal etc
Suitable Location	Conveyor head roller

Materials

Magnetic Material	Rare Earth Neodymium Iron Boron - (NdFeB)
Cover	304 grade stainless steel
End Cheeks	Painted mild steel
Shaft	Mild steel

Cleaning

The unit is continuously self cleaning. Contamination enters the roller's magnetic field where it is attracted and held firmly on the belt. When it reaches the underside it passes out of the magnetic field and is discharged separately from the conveyed product, which continues on its normal trajectory.

Options

- Ceramic magnetic material
- Rubber lagged diamond cut cover
- Crowned detail
- Protective paint coating

*Mild steel test piece Ø 5mm x 25mm long

*Excluding rubber lagged units

Permanent Magnet Head Roller

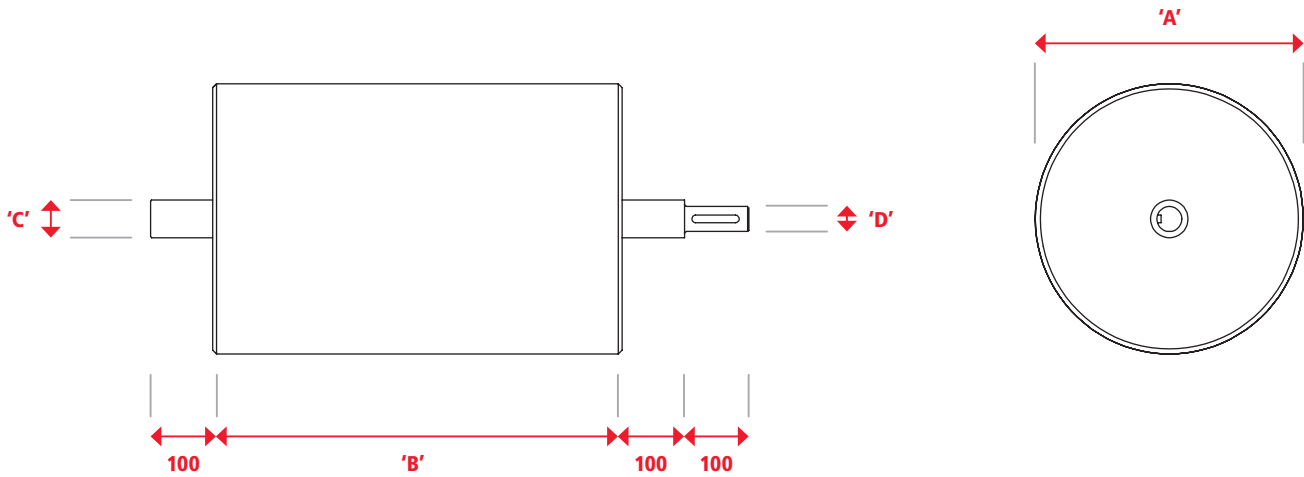

Part Number (200 Series)	Diameter A (mm)	B (mm)	Dia. C (mm)	D (mm)	Weight (kg)
HRN2140	215	400	40	30	70
HRN2150	215	500	40	30	80
HRN2160	215	600	40	30	95
HRN2170	215	700	40	30	110
HRN2180	215	800	40	30	130
HRN2190	215	900	40	30	145
HRN21100	215	1000	40	30	160

Part Number (300 Series)	Diameter A (mm)	B (mm)	Dia. C (mm)	D (mm)	Weight (kg)
HRN3140	315	400	50	40	110
HRN3150	315	500	50	40	130
HRN3160	315	600	50	40	150
HRN3170	315	700	50	40	170
HRN3180	315	800	50	40	190
HRN3190	315	900	50	40	210
HRN31100	315	1000	50	40	230

Part Number (400 Series)	Diameter A (mm)	B (mm)	Dia. C (mm)	D (mm)	Weight (kg)
HRN4040	400	400	60	50	220
HRN4050	400	500	60	50	260
HRN4060	400	600	60	50	300
HRN4070	400	700	60	50	340
HRN4080	400	800	60	50	380
HRN4090	400	900	60	50	420
HRN40100	400	1000	60	50	460

For non-standard sizes, please contact sales@eclipsemagnetics.com

Permanent Plate Magnet



At A Glance



Protection: Primary



Feed Type: Conveyor



Material Type: Ferrite



Cleaning Type: Manual

Permanent plate magnets are used in recycling, quarrying and heavy industries. These units can be placed above flat or trough type conveyors. Large permanent magnetic packs generate deep penetrating magnetic flux fields that attract and remove 'tramp' type steel items.

This unit is considerably less expensive than electro-magnetic units and, as it has no running costs other than cleaning, much cheaper to run. When considering installation points it should be noted that steel belt support rollers will need to be changed to non-magnetic ones due to possible flux field absorption. For heavily contaminated materials consider the self cleaning permanent magnetic overband.



Benefits

- High volume capacity
- Allows difficult products to be screened
- Designed for 24 / 7 operation
- Removes large to medium sized contamination

Performance

Magnetic Performance	3,000 Gauss
Magnetic field depth	100 Series = 100mm*, 200 Series = 200mm*
	300 Series = 300mm*
Temperature	-40°C / +80°C

Suitability

Suitable Products	All conveyable products, wood chip, biomass, recyclables, aggregates, coal etc
Suitable Location	Above transfer conveyors, vibratory feeder outlets etc

Materials

Magnetic Material	Ceramic strontium ferrite
Cover	304 grade stainless steel
Back plate	Painted mild steel
Lifting points	Four threaded holes

Cleaning

The magnetism cannot be switched off so cleaning has to be done manually using either a scraper tool or gloved hand. To aid cleaning, plate magnets can be supplied with a sliding cleaning plate.

Options

- Sliding cleaning plate
- Full stainless steel cover
- Forged lifting eyes
- Protective paint coating

*Mild steel test piece Ø 5mm x 25mm long

Permanent Plate Magnet

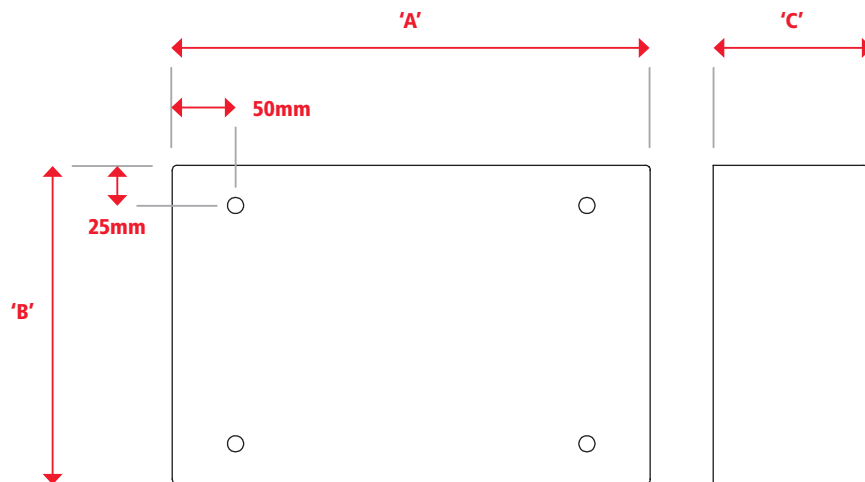

Part Number (100 Series)	Length A (mm)	Width B (mm)	Depth C (mm)	Thread (mm)	Weight (kg)
PM3020	300	200	100	M12	40
PM4020	400	200	100	M12	50
PM5020	500	200	100	M12	65
PM6020	600	200	100	M12	85
PM7020	700	200	100	M12	95
PM8020	800	200	100	M12	105
PM9020	900	200	100	M12	120
PM10020	1000	200	100	M12	135

Part Number (200 Series)	Length A (mm)	Width B (mm)	Depth C (mm)	Thread (mm)	Weight (kg)
PM4040	400	400	200	M16	220
PM5040	500	400	200	M16	265
PM6040	600	400	200	M16	320
PM7040	700	400	200	M16	370
PM8040	800	400	200	M16	420
PM9040	900	400	200	M16	470
PM10040	1000	400	200	M16	530

Part Number (300 Series)	Length A (mm)	Width B (mm)	Depth C (mm)	Thread (mm)	Weight (kg)
PM6080	600	800	300	M20	730
PM7080	700	800	300	M20	850
PM8080	800	800	300	M20	970
PM9080	900	800	300	M20	1100
PM10080	1000	800	300	M20	1200
PM12580	1250	800	300	M20	1450

For non-standard sizes, please contact sales@eclipsemagnetics.com

Permanent Magnetic Overband

At A Glance



Protection: Primary



Feed Type: Conveyor



Material Type: Rare Earth



Cleaning Type: Automatic

Permanent overband magnets are used in recycling, quarrying and heavy industries. These units can be placed above flat or trough type conveyors. Large permanent magnetic packs generate deep penetrating magnetic flux fields that attract and remove 'tramp' type steel items.

This unit is considerably cheaper to purchase and run than electro-magnetic units, the only power consumption is for the geared drive.

When considering installation points it should be noted that steel belt support rollers will need to be changed to non-magnetic ones due to possible flux field absorption.

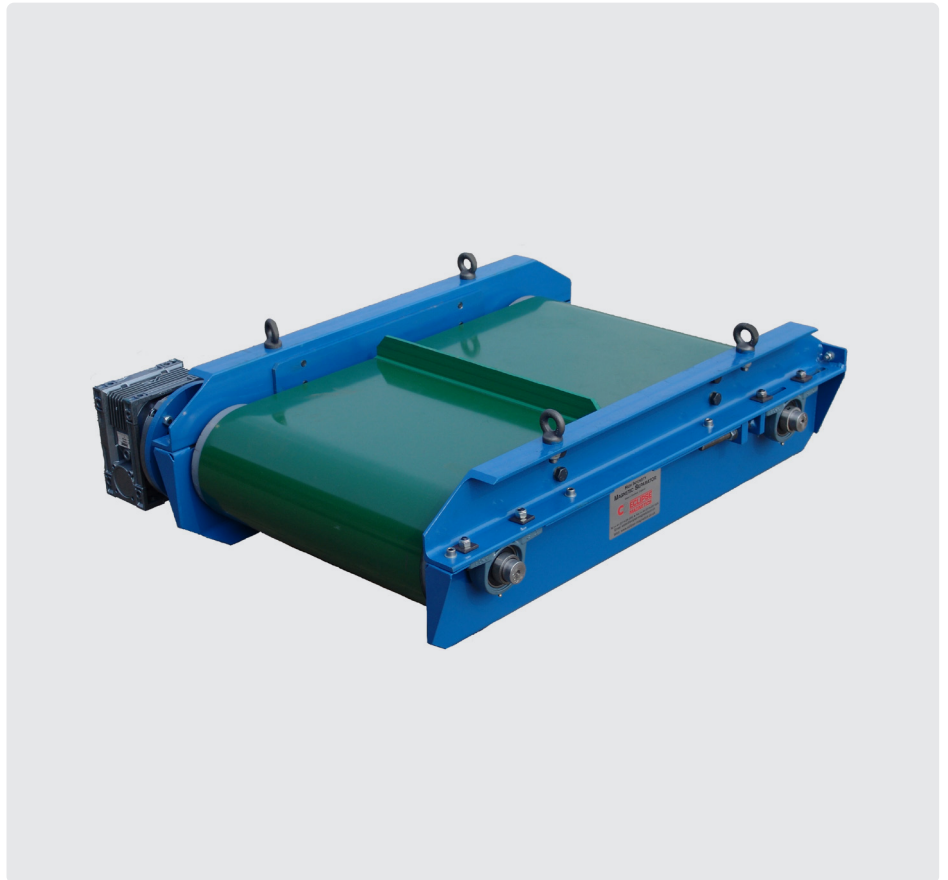

Benefits

- Continuous self cleaning
- Allows difficult products to be screened
- High volume capacity
- Designed for 24 / 7 operation
- Removes large to medium sized contamination

Performance

Magnetic Performance	3,000 Gauss
Magnetic field depth	100 Series = 100mm*, 200 Series = 200mm* 300 Series = 300mm*
Electrical Spec	415 / 380 Volts industrial three phase IP65 rated motor gearbox
Temperature	-20°C / +60°C

Suitability

Suitable Products	All conveyable products, wood chip, biomass, recyclables, aggregates, coal etc
Suitable Location	Above transfer conveyors, vibratory feeder outlets etc

Materials

Frame	Powder coated mild steel
Rollers	Mild steel
Belting	Vulcanised rubber with ultrasonically welded cleats
Lifting Points	Galvanised forged steel eyes

Cleaning

Overband magnets have a continuously running belt which takes away and deposits all attracted contamination. Carry-over cleats are fitted to ensure that contamination cannot remain on the belt. It can operate 24 / 7 operation without operator intervention.

Options

- Safety electrical interface
- Hydraulic drive motor
- Armoured belting
- Tapered rollers to enable angled operation

*Mild steel test piece Ø 5mm x 25mm long

Permanent Magnetic Overband

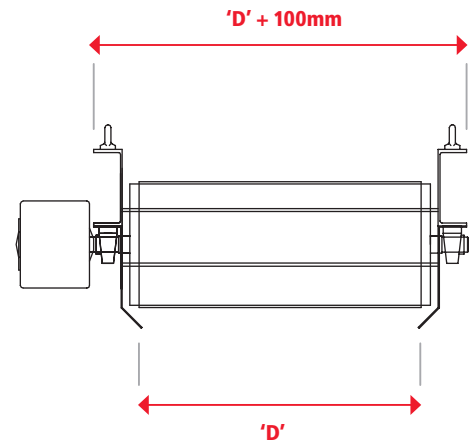
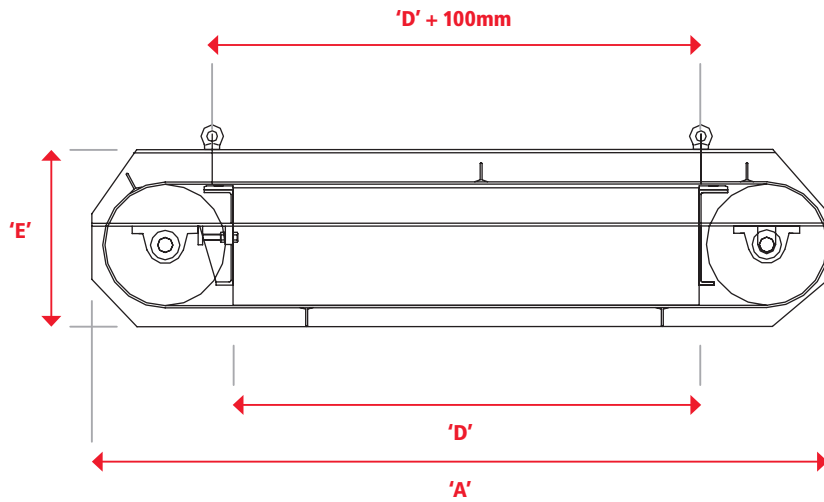

Part Number (100 Series)	A (mm)	B / C (mm)	D (mm)	E (mm)	Motor (kW)	Weight (kg)
OM100/300	718	350	300	125	0.18	160
OM100/450	868	350	450	125	0.18	205
OM100/550	968	350	550	125	0.18	240
OM100/650	1068	350	650	125	0.18	270

Part Number (200 Series)	A (mm)	B / C (mm)	D (mm)	E (mm)	Motor (kW)	Weight (kg)
OM200/550	1069	600	550	345	1	680
OM200/650	1169	600	650	345	1	770
OM200/850	1419	600	850	345	1	820
OM200/1050	1619	600	1050	345	1.5	970
OM200/1250	1819	600	1250	345	2.2	1120

Part Number (300 Series)	A (mm)	B / C (mm)	D (mm)	E (mm)	Motor (kW)	Weight (kg)
OM300/800	1474	800	800	460	1.5	1700
OM300/1050	1724	800	1050	460	2.2	2150
OM300/1250	1924	800	1250	460	2.2	2500
OM300/1500	2174	800	1500	460	2.2	2850
OM300/1750	2424	800	1750	460	2.2	3200

For non-standard sizes, please contact sales@eclipsemagnetics.com

Customised Solutions

High performance Foreign Body Removal systems to bespoke specifications

Our 100 years' of magnetic expertise and our deep knowledge of processing industries enable us to work with our clients to provide the optimum solution.

If a standard product is not the answer we can offer a tailor-made solution. This could be an adaptation of a standard separation system or a complete new system. With in-house design expertise and the latest CAD and FEA software we can provide bespoke Foreign Body Removal systems in condensed lead times.

Our consultation service involves visiting your site, assessing your application or process and identifying the optimum solution. We can offer bespoke designs, different grades of magnet material, surface finishes, ancillary equipment or cleaning methods.



Pharmaceutical specification double row housed easy clean grid, pre and post sifter protection.



Housed easy clean grid with 4 rows and track system designed for large bulk flow applications.

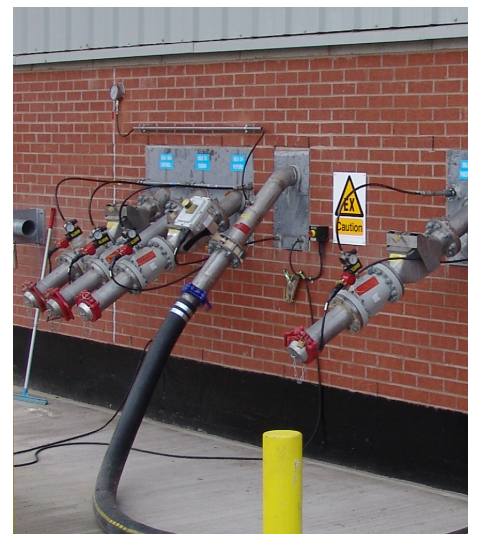

Pneumag installed at bulk material intake, ATEX rated.



High capacity magnetic liquid filter finished to pharmaceutical specification.

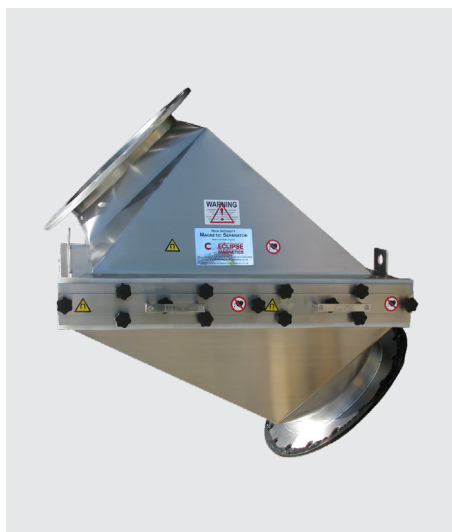

Housed easy clean grid manufactured to fit an inclined gravity chute.



Easy Clean Grid Separator acts as a sack rip and tip station.

Equipment Testing & Site Surveys

Satisfy your audit requirements with our testing and validation service

Our dedicated site inspection and validation service provides the necessary information to comply with external BRC or customer audit requirements. Our site inspection service includes:

- Visual inspection of magnetic equipment
- Magnetic performance testing (by Gauss meter)
- Appraisal of installations and applications
- Issue of test certification (where pass rate achieved)
- Assessment report and recommendations

In line with HACCP procedures it is vital that critical Foreign Body Removal equipment such as magnetic separators and metal detectors are assessed annually.

The performance of magnetic equipment can vary depending on the age, design, product type or operating conditions. It is important to have annual performance tests to maintain high levels of protection.

Our dedicated mobile service team provide a comprehensive assessment and certification for audit requirements by a qualified engineer. In addition, if you take out one of equipment service contracts we will plan your service schedule and contact you when the equipment service is due and arrange a time to visit.



Gauss Meter

The Eclipse Magnetics digital Gauss Meter can be used to assess the strength of existing magnetic separation equipment either pre- or post-audit. This unit has many beneficial features and is supplied, ready to use, fully calibrated and complete with a transverse probe. Supplied in a robust carry case the meter can be used in the most arduous of environments.

Specification

+ / - 2% or 10 Gauss (whichever is the greater)
Units, Gauss, Tesla, Ampere Metres or Oersted
Operating temperature 0°C to +50°C
20 hours battery life, continual use
LCD Display, 16 characters
Weight 0.42 (kg)
Size 195mm x 101mm x 44mm



The latest generation in metal detection ensures total product integrity while being easy to operate with maximum effectiveness. The range has a robust construction, a choice of multi-frequency search heads and features the interact control panel.

Official Partner for SESOTEC in the UK

Eclipse Magnetics is proud to be the official Partner for SESOTEC products in the UK, meaning that in addition to our current range of magnetic separation products and we also offer an impressive range of metal detection systems, and X-ray detection systems.

Forefront of Product Quality

The range provides outstanding detection performance, reliability and accuracy. It detects all ferrous and non-ferrous metals in packaged or non-packaged items. Our systems come complete with full operation manuals, drawing specifications, performance test samples and declarations of conformity.

Meeting Industry Standards

We are fully conversant with all major government food safety policies, such as FSA, FDA and IFS, and those of other institutes, including BRC and GFSI.

Total Customer Support

Eclipse Magnetics has a team of fully trained service engineers who can carry out on site servicing, testing and repair.

Reject Mechanisms

Our range is available with a choice of reject mechanisms:

- Push/pull paddle
- Diverter flap
- Swing arm
- Air blast system

Sensing and Alerts

A choice of sensors and warning options are available to ensure safe operation:

- Audio alarms
- Visual beacons
- Push-button re-set
- Detector fault warnings

Tailor Made Packages

We can manufacture and build detection systems to your specific requirements. Our engineers will visit your site to assess your inspection requirements and operating conditions before suggesting the package and features required.

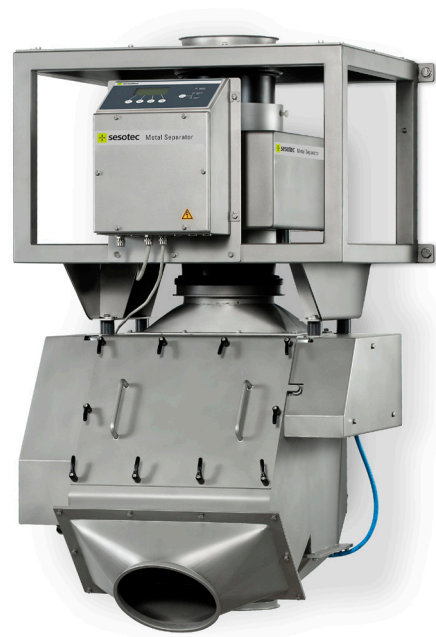

Bulk Goods and Powder Metal Detection

Gravity feed metal detection systems from Eclipse Magnetics provide complete protection for your process line. Designed specifically to inspect granular and powdered free falling bulk products, our systems are easily integrated into existing process lines to facilitate HACCP systems and comply with safety standards.

Our metal detection systems are fully automatic in operation, and remove any metallic contaminants from bulk materials such as granulate, powder, or flour. As the metal particles are captured from bulk materials, they are then removed using either a reject flap or a swivel funnel. Easily available standard connections mean that systems can be integrated into existing pipes with minimal effort.

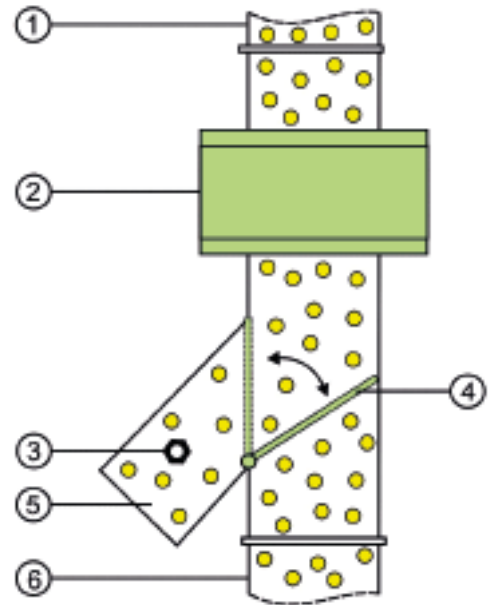

- 1) Inlet
- 2) Detection coil
- 3) Metal contaminant
- 4) Reject flap
- 5) Reject outlet
- 6) Material outlet

Featured Products



For Suction and Pneumatic Conveying Lines

Pneumatic feed metal detectors are designed to detect and reject metal contamination from pneumatic conveyor pipes, and perfect for high flow rate vacuum conveying or suction lines. By detecting and rejecting metal contamination, our pneumatic feed metal detectors reduce the risk of damage to machinery, reduce the risk of product recalls, and increase process performance, providing a great return on investment.

For Suction and Pneumatic Conveying Lines

Our pneumatic feed metal detection systems can be integrated quickly and easily into existing vacuum or pressure conveyor pipes. Even at high temperatures and high conveying speeds, they reliably remove contaminants from pneumatically conveyed bulk goods with minimal loss of material. Suitable for use in the plastics-processing, chemical, pharmaceutical, and food industries, our metal detection systems can be used in conjunction with a pneumatic feed magnetic separator to provide a full turnkey and high performance solution for removing metal contamination from your process line.

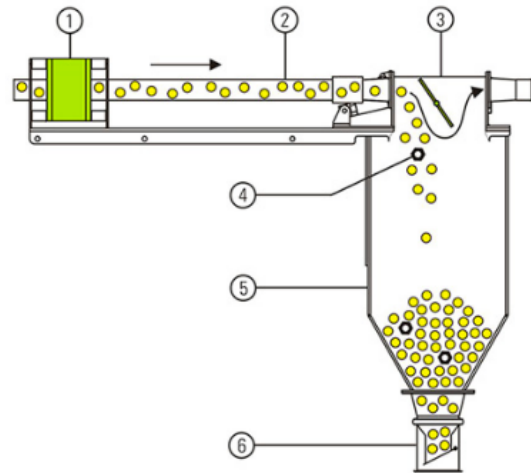

- | | |
|--------------------|-----------------------------|
| 1. Dection coil | 5. Collecting tray |
| 2. Detection tube | 6. Shutter valve |
| 3. Separation unit | (used for vacuum pipelines) |
| 4. Metal | |

Featured Products



End of Line Tunnel Metal Detection System

Tunnel Metal detection systems are perfect for end of line detection of metal contamination. Positioned on conveyors or chutes our tunnel systems allow for the inspection of bulk or packed goods.

Our systems can be fitted onto existing conveyor lines, or have an integrated conveyor system. Our hygienic housing design allows for efficient cleaning and complies with food and safety standards. Smart sensitivity adjustment and intuitive software design helps avoid inaccurate activation and detection.



Tunnel metal detector DLS analysing recycling material before the granulator

Featured Products





Europe

Atlas Way
Sheffield
S4 7QQ
England

T +44 (0)114 225 0600
F +44 (0)114 225 0610
sales@eclipsemagnetics.com

Americas

442 Millen Road, Unit 9,
Stoney Creek
Ontario, L8E 6H2,
Canada

T +1 905-664-5585
F +1 905-664-7090
sales@eclipsetoolsinc.com

China

No. 168 Chengjian Road
Minhang District
Shanghai
PR China

T +86 21 6434 8600 *150
F +86 21 6434 6488
szhou@eclipsemagnetics.com

Representative:

www.eclipsemagnetics.com

Eclipse Magnetics Ltd

Atlas Way, Atlas North, Sheffield, S4 7QQ, England
T +44 (0)114 225 0600 F +44 (0)114 225 0610
info@eclipsemagnetics.com www.eclipsemagnetics.com

While every effort has been made to ensure the accuracy of the information in this publication please note that specifications may change without notice.