

Magnetic Separation & Metal Detection Systems

Foreign Body Protection for Crystallized Sugar Processing



Protecting sugar processes from metal contamination

Eclipse Magnetics has vast experience in the sugar processing industry, we provide high performance magnetic separators and metal detection equipment to many of the largest beet and cane refineries worldwide. Our separation systems play a crucial role in protecting much of the estimated 180 million tonnes of annual worldwide sugar production.

Our systems are an integral part of robust HACCP plans (Hazard Analysis and Critical Control Points), as determined by International Food Safety Standard ISO 22000.

With sugar refiners' margins under pressure from increasing raw material prices and price reductions from customers, it is important that wastage is kept to a minimum.

Our magnetic separation systems and metal detectors are widely used post screening / scalping process to remove fine metal particles and tramp metal, which may have entered the process. All our products are carefully engineered to handle high volume production and meet strict hygiene standards.

Your Process is at Risk

Sugar refining processes are at risk from metal contamination made up of a mixture of ferrous, non-ferrous and stainless steel particles. This can enter the process as a result of process wear, degradation of plant equipment or engineering work.

*Typical particulate removed by magnet

If this contamination is not removed it presents enormous safety and financial risks such as:-

- Costs of product recalls
- Costs of disposing of defective batches
- Costs of loss of customer confidence and brand damage
- Consumer safety risks



Removing Contamination - Magnetic Separation

Our range of separators and metal detectors minimise the risk of ferrous, non-ferrous and para-magnetic metals from entering the finished product. Our range includes:-

Auto-Shuttle Magnetic Separators

The Auto-shuttle is ideal for installation on the gravity feed from the screening/ scalping process to the silos or holding bins. It's high intensity magnetic circuit ensures even the finest magnetic and para-magnetic particles are removed from the process.

- Fully Automated, gives 24/7 protection
- On board PLC – can be supplied to integrate with central control room software (Allan Bradley and Siemens available on request)
- 2 or 3 row magnet design ensures continuous processing whilst cleaning
- ATEX certified
- Premium quality surface finish (0.8 Ra μm)
- Ideal for high volume process lines, up to 300 tonnes per hour
- Manually cleaned units also available

**24/7
Protection**



For detailed specifications please contact us.

A Typical Sugar Processing Separation and Detection Installation

Our separation systems provide 24/7 automated protection for high volume process lines, without any need for manual intervention or line stoppages. Using the latest grades of high strength magnet materials and optimised flow dynamics our systems remove the finest magnetic and para-magnetic contamination.

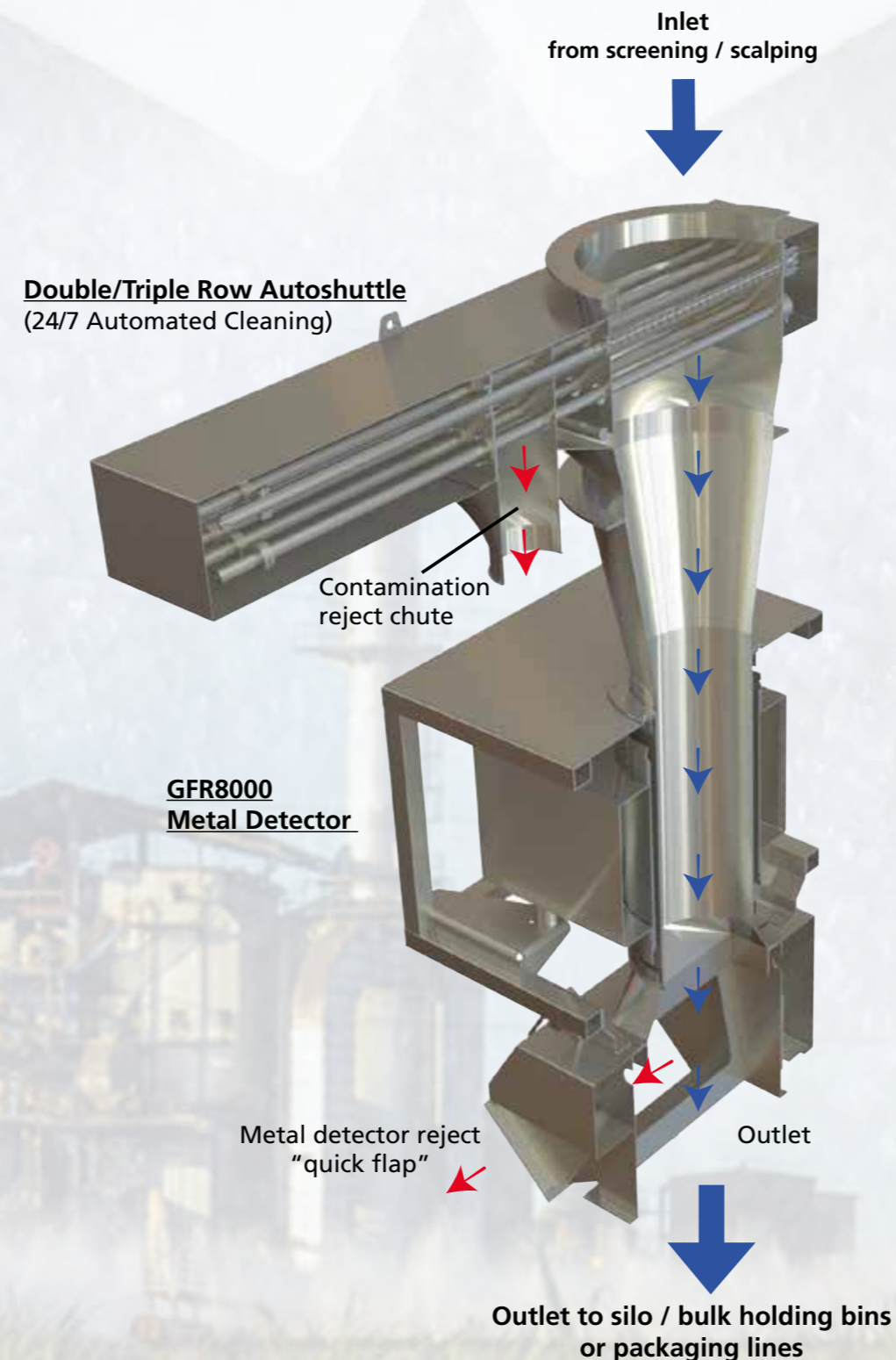

High performance Metal Detection



GFR8000 Metal Separator

The GFR 8000 metal separator is used for the inspection of bulk materials in free-fall conveyor pipes starting from a nominal width of 200 mm. It detects all magnetic and non-magnetic metal contaminations (steel, stainless steel, aluminium, ...) - even if such contaminations are embedded in the product. Metal contaminations are rejected by means of a swivel hopper. The reject outlet is of dust-proof design during normal operation.

The GFR 8000 metal separator primarily is used in the food industry in applications with high hygienic demands.

**24/7
Protection**

- Hi-tech detector head identifies and diverts contaminated contents to a reject outlet
- Ideal for bulk volume processes
- Intuitive controller with LCD display
- Integration with central control also available
- Hygienic design for easy cleaning
- Separation unit and product-contacting metal parts completely made of stainless steel 1.4301(AISI 304)
- Highest scanning sensitivity for all metals
- Multi-product memory
- Highest sensitivity for all metals (2-channel technology)
- Digital signal processing and quartz-stable search frequency
- State-of-the-art microprocessor technology with self-monitoring, auto-balancing, and temperature compensation
- Product compensation with auto-learn function
- Multi-product memory
- Password protection / access protection
- Special EMC combination filter for suppressing external interference

For detailed specifications please contact us.

Other products

Experts in Foreign Body Removal

In addition to the sugar industry our products are used in almost every processing industry to remove ferrous and para-magnetic contamination from process lines, preventing product contamination and damage to machinery.

We produce high-quality, high-power magnetic separators for most applications, including bulk, grain, dry powders, liquids and syrups and a comprehensive range of metal detectors and vibratory sieves. We also offer a testing and validation service for existing equipment.

Standards/Approvals

We are fully conversant with all major industry standards such as FSA, FDA and IFS, plus institutes such as BRC and GFSI. Many of our magnetic separation products have full ATEX certification.

Eclipse Magnetics Worldwide



France

Eclipse Magnetics Ltd
BP7 59239
Thumeries
France

Tel: +33(0) 320 172691
Fax: +33(0) 648 277994
lpirez@eclipsemagnetics.com

North/Central/South America

Eclipse Tools North America
442 Millen Road, Unit 9
Stoney Creek
Ontario
L8E 6H2

Tel: 001 905 664 5585
Fax: 001 905 664 7090
sales@ecliptoolsinc.com

Europe

Eclipse Magnetics Ltd
Atlas Way
Sheffield
S4 7QQ

Tel: +44 (0)114 225 0600
Fax: +44 (0)114 2250610
info@eclipsemagnetics.com

Australia

Spear & Jackson (Australia)
Building 2 82 Greens Road
Dandendong
South Victoria, Australia

Tel: +613 8792 9999
Fax: +613 8792 9900
sales@spear-and-jackson.com.au

China

Bowers Eclipse
No. 168 Chengjian Road
Minhang District
Shanghai, PR China

Tel: 0086 21 6434 8600
Fax: 0086 21 6434 6488
szhou@eclipsemagnetics.com

If you require more information or a quotation please contact info@eclipsemagnetics.com or telephone **+44 (0)114 225 0600** or visit www.eclipsemagnetics.com